

BCPUN1(NF)

Aufbauanleitung

DE - Bevor Sie beginnen:

- Es ist empfehlenswert sich etwas Zeit zu nehmen, um die Aufbauanleitung zu lesen, bevor mit dem Aufbau begonnen wird.
- Der Aufbau sollte in der vorgegebenen Reihenfolge erfolgen.
- Die Aufbauanleitung dient lediglich als Richtschnur für den Aufbau. Nicht alle Schritte sind im Detail vorgegeben.
- Bitte prüfen Sie alle Teile auf Vollständigkeit und Zustand vor dem Aufbau. Der Aufbau sollte durch mindestens 2 Personen erfolgen.
- Bei starkem Wind sollte der Aufbau nicht erfolgen.
- Bohren Sie die Teile vor, wo es angezeigt wird.
- Wir empfehlen, das Gerätehaus erst nach weitgehendem Aufbau vor Anbringung der Deckleisten mit Farbe oder Holzlasur zu behandeln, da sich die Elemente bei einer einseitigen Behandlung verziehen können, wodurch der Aufbau erschwert werden könnte.

Instructions d'assemblage

FR - Avant de commencer:

- Avant de commencer le processus d'assemblage, veuillez s'il vous plaît vous familiariser parfaitement avec les instructions.
- La maison doit être assemblée suivant la séquence indiquée dans les instructions.
- Les instructions s'entendent comme lignes directrices, toutes les étapes ne sont pas décrites en détails.
- Avant de commencer l'assemblage, vérifier tous les éléments.
- Deux personnes sont nécessaires au minimum pour l'assemblage.
- Ne pas tenter d'assembler la maison dans des conditions de vents forts.
- Percer les trous dans les éléments suivant les marques.

Montage-instructie

NL - Alvorens te beginnen:

- Voordat u begint met de montage raden wij u aan de handleiding grondig door te lezen.
- Bij de montage van het huis dient u de volgorde zoals deze in de handleiding is aangegeven te volgen.
- De handleiding is bedoeld als richtsnoer, niet alle stappen zijn in detail uitgewerkt.
- Vóór de montage dienen alle details gecontroleerd te worden.
- De montage van het huis dient door tenminste twee personen uitgevoerd te worden.
- Het huis nooit in harde wind opbouwen.
- Gat in onderdelen boren, waar dit staat aangegeven.

Pokyny k montáži

CZ - Než začnete:

- Než začnete s montáží, seznámte se důkladně s těmito pokyny.
- Domek musí být sestaven v pořadí uvedeném v pokynech.
- Pokyny slouží pouze jako vodítko, ne všechny kroky jsou zde popsány dopodrobna.
- Než začnete s montáží, zkontrolujte všechny díly.
- K montáži jsou zapotřebí minimálně dvě osoby.
- Nepokoušejte se smontovat domek za silného větru.
- Vyvrtejte do dílů otvory podle značek.

Pokyny pre montáž

SK - Predtým, než začnete:

- Predtým, než začnete montovať, sa, prosím, dôkladne oboznámte s týmito pokynmi.
- Dom je potrebné zmontovať podľa poradia uvedeného v pokynoch.
- Tieto pokyny poskytujú návod, nepopisujú však detailne všetky kroky.
- Predtým, než začnete montovať, skontrolujte všetky časti.
- Pri montáži sú potrební najmenej dvaja ľudia.
- Nepokúšajte sa montovať dom pri silnom vetre.
- Otvory v jednotlivých častiach vyvrtajte podľa označenia.

DE - Technische Änderungen vorbehalten.







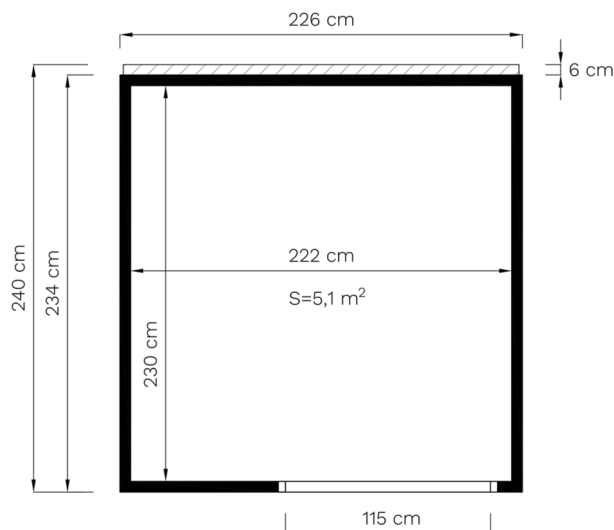
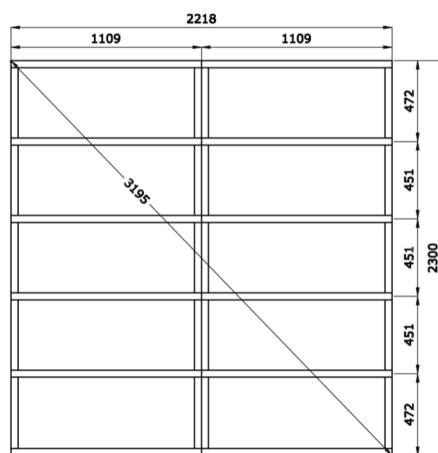
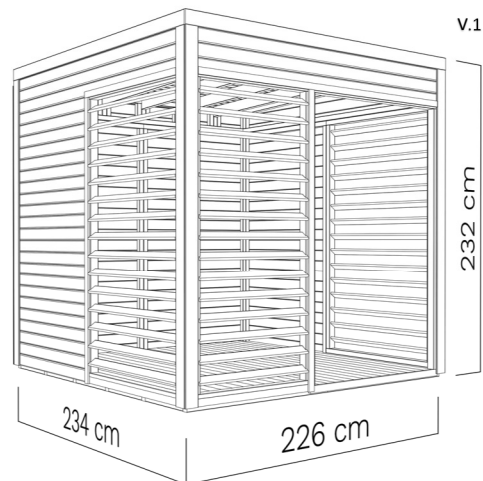



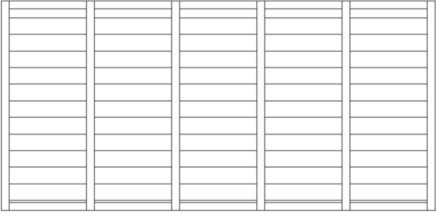
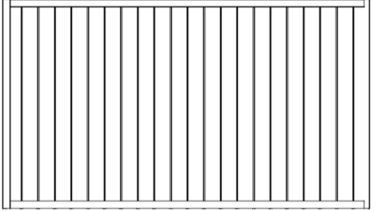
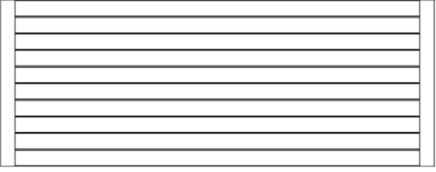





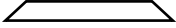



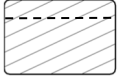
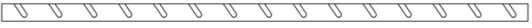
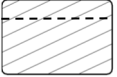







Alle Maße sind ca. Maße.

EN - Technical modifications reserved.

All dimensions are approximate dimensions.



BCPUN1(NF)

ID	Details in mm (Tolerance/Toleranz ...+ 2mm)	Pcs.	ID	Details in mm (Tolerance/Toleranz ...+ 2mm)	Pcs.
147	60 x 1109 x 2300 	x 2	148	60 x 1109 x 1953 	x 4
156	38 x 792 x 2218 	x 3	791	19 x 88 x 2218 	x 2
152	60 x 350 x 2218 	x 1	153	60 x 224 x 2218 	x 1
154	60 x 314 x 2218 	x 1	155	60 x 314 x 2218 	x 1
906	40 x 80 x 2295 	x 5	857	40 (41) x 60 (41) x 500  	x 6
869	40 x 60 x 1878 	x 2	1099	41 x 41 x 1918 	x 2
1056	40 x 60 x 1836  	x 3	1065	40 x 60 x 1836  	x 3
1066	40 x 60 x 1109 	x 4	1067	40 x 60 x 900 	x 2
1068	40 x 60 x 1236 	x 1	756	19 x 45 x 2245 	x 4
1070	19 x 41 x 1936 	x 2	1071	19 x 45 x 1109 	x 2
1072	19 x 45 x 900 	x 1	1073	19 x 45 x 1236 	x 1
1075	19 x 70 x 1049 	x30	1076	19 x 70 x 840 	x 15
668	12 x 90 x 2200 	x 9	671	12 x 90 x 2286 	x 1
642	12 x 90 x 1170 	x 4	1078	12 x 42 x 2100 	x 1
595	12 x 42 x 1926 	x 3	1080	12 x 42 x 1100 	x 2

BCPUN1(NF)

ID	Details in mm (Tolerance/Toleranz ...+ 2mm)	Pcs.	ID	Details in mm (Tolerance/Toleranz ...+ 2mm)	Pcs.
540	3 x 1000 x 2600 NB! Roofing felt for initial covering!	x 3	1502	∅4,5 x 75	x 166
1505	∅4,5 x 50	x 177	1506	∅3,5 x 35	x 147
1514	∅3 x 14	x 154			

NB!

Empfohlen bei Aufbau auf besonders feuchtem Untergrund.

Recommended for assembly on moist ground.

* Nicht im Lieferumfang enthalten / Not included!

* Unterlagspad /

* Patio Pads

Min. 13,5 lfm/rm

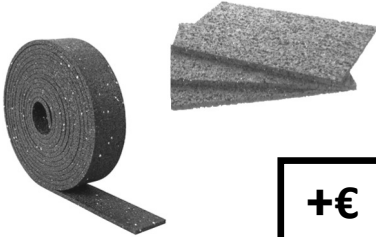

+€

* Imprägniert Kantholz /

* Impregnated beam

40*60*2218 mm

6 Stck/Pcs

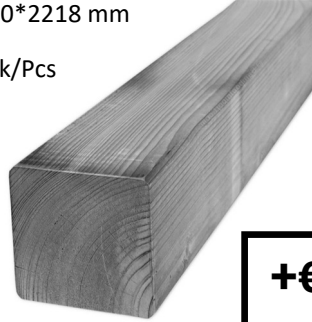

+€

* Schraube /

* Screw

4,5*80 mm

36 Stck/Pcs



+€

Fundamentplan / Foundation Plan

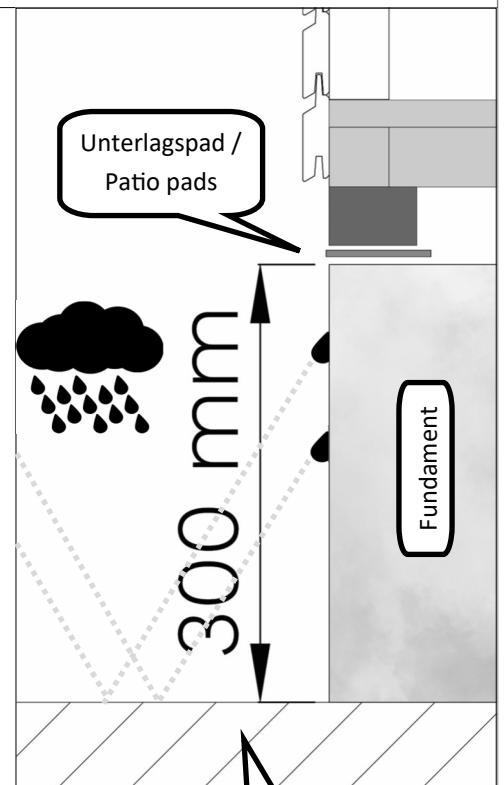
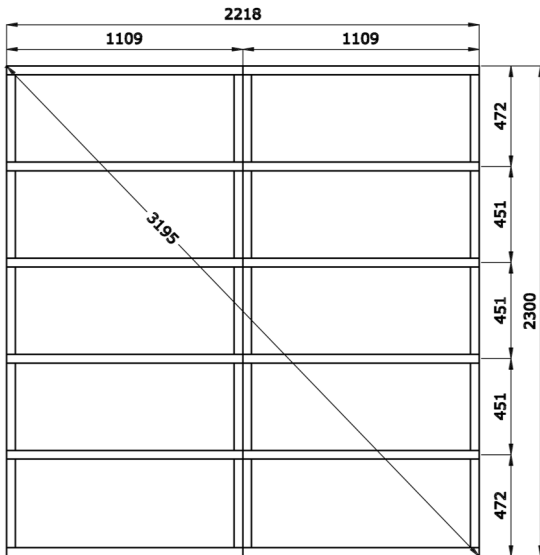

Imprägniertes Kantholz /
Impregnated beam

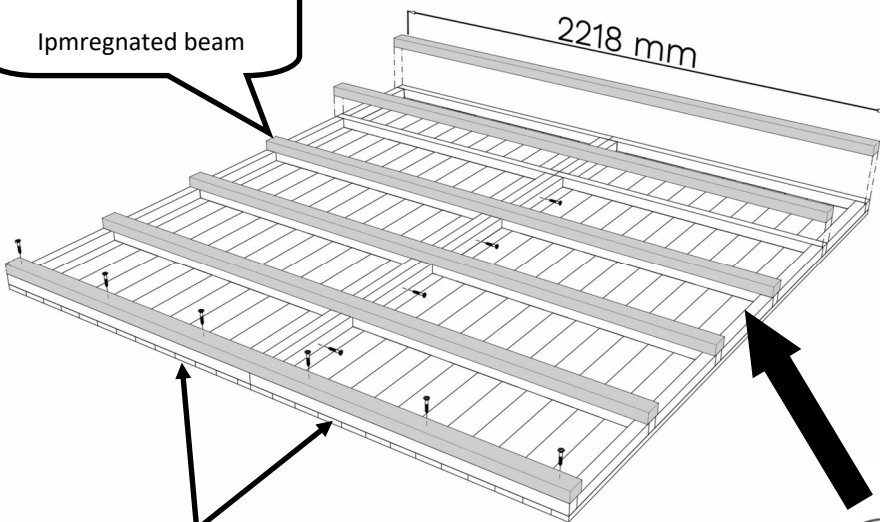

147

Holzschutzmittel / Wood preservative



Bitte beachten!

Lass Dein Bauvorhaben vorab bei Deiner zuständigen Gemeinde prüfen, denn die Bauordnungen sowie die Bebauungspläne müssen eingehalten werden.

Please note!

Have your construction project checked in advance at your responsible municipality, because the building regulations and the development plans must be observed.

BCPUN1(NF)

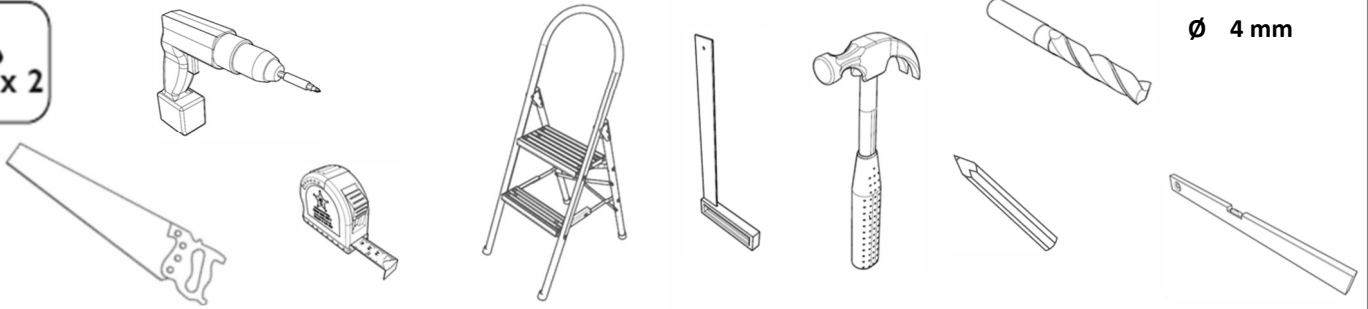

Ø 4 mm

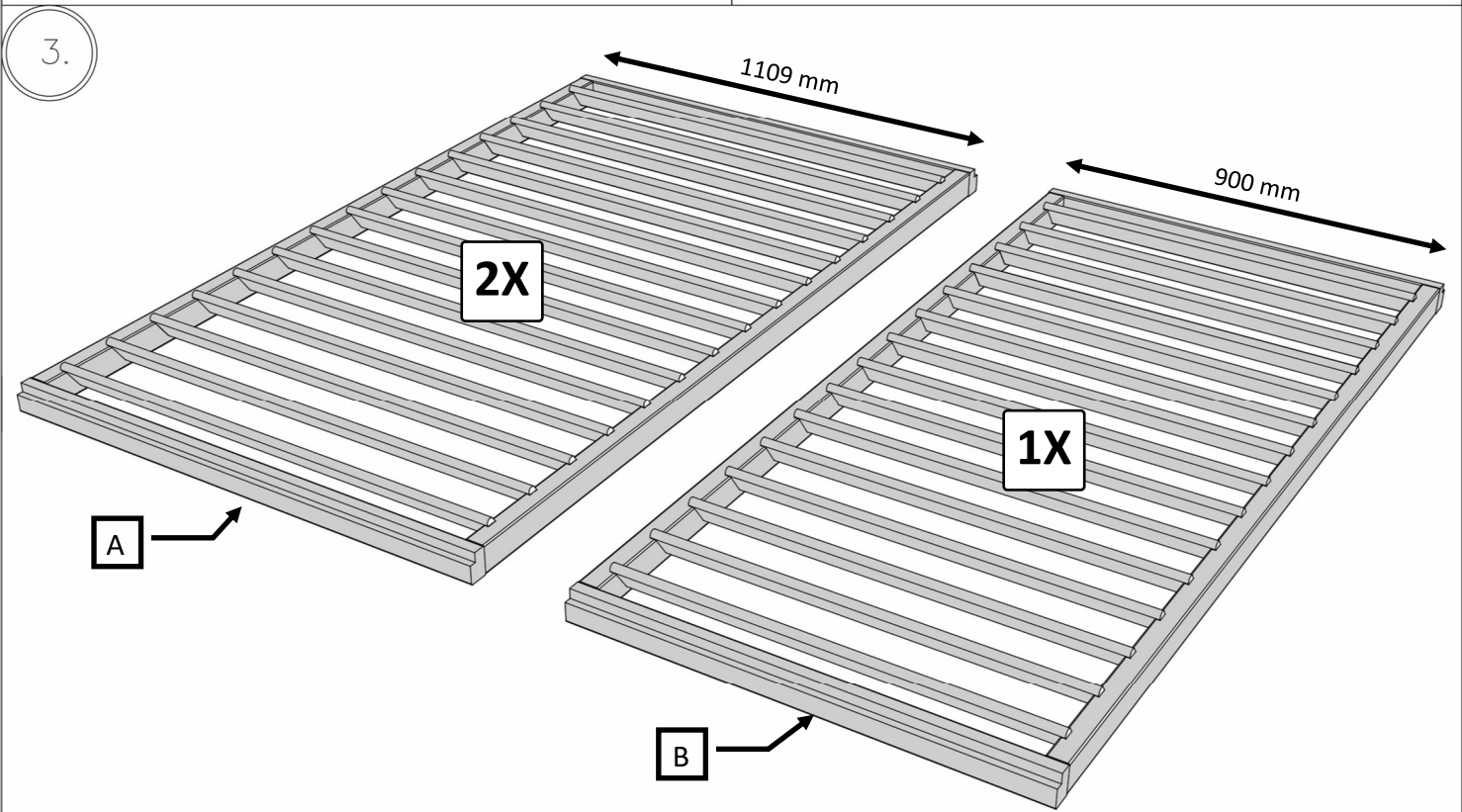
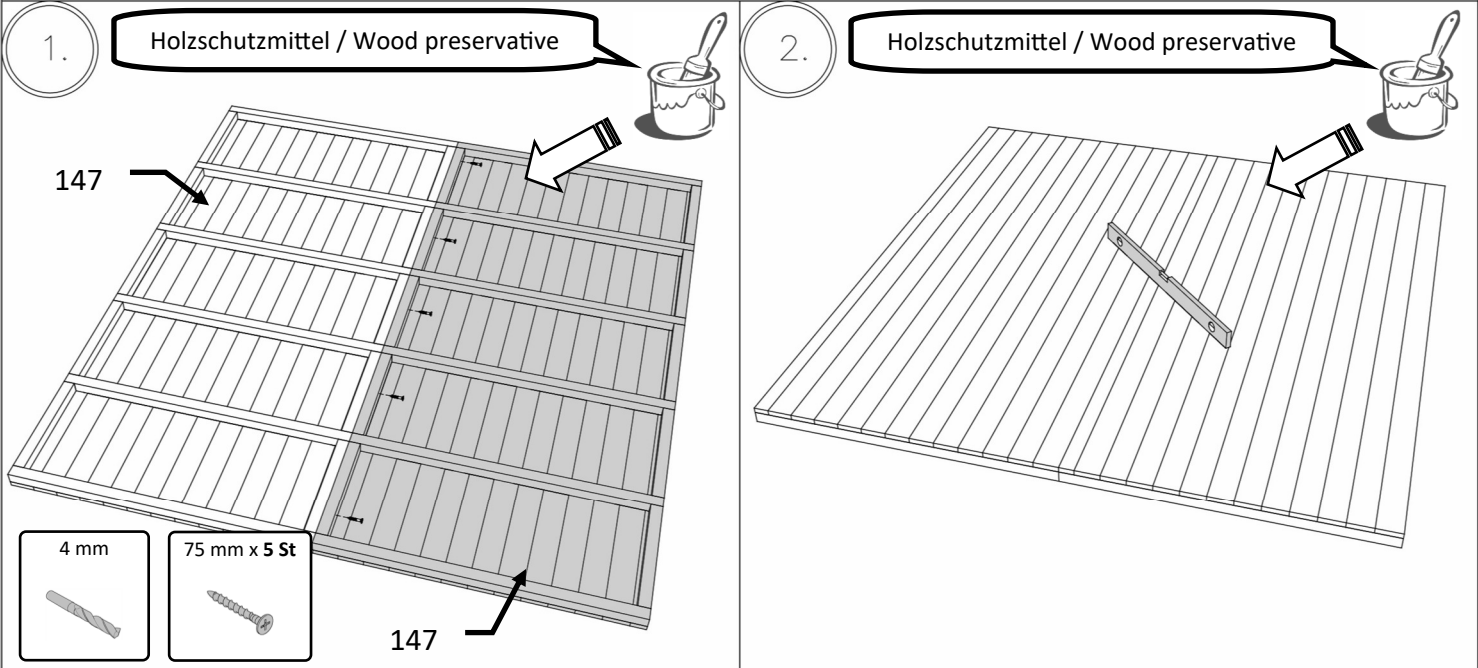

BCPUN1(NF)

4.

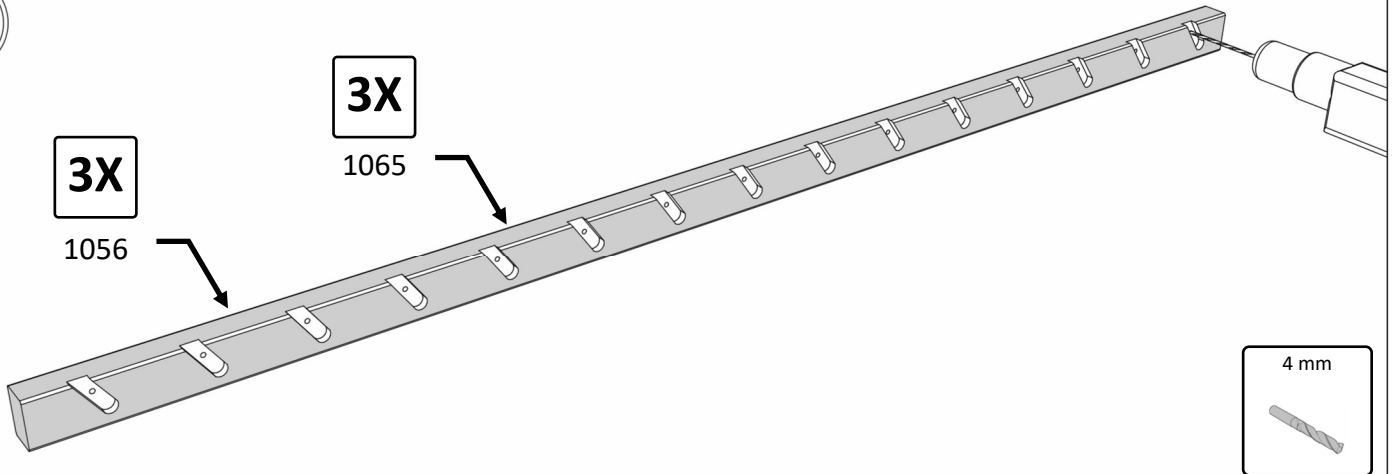

5.

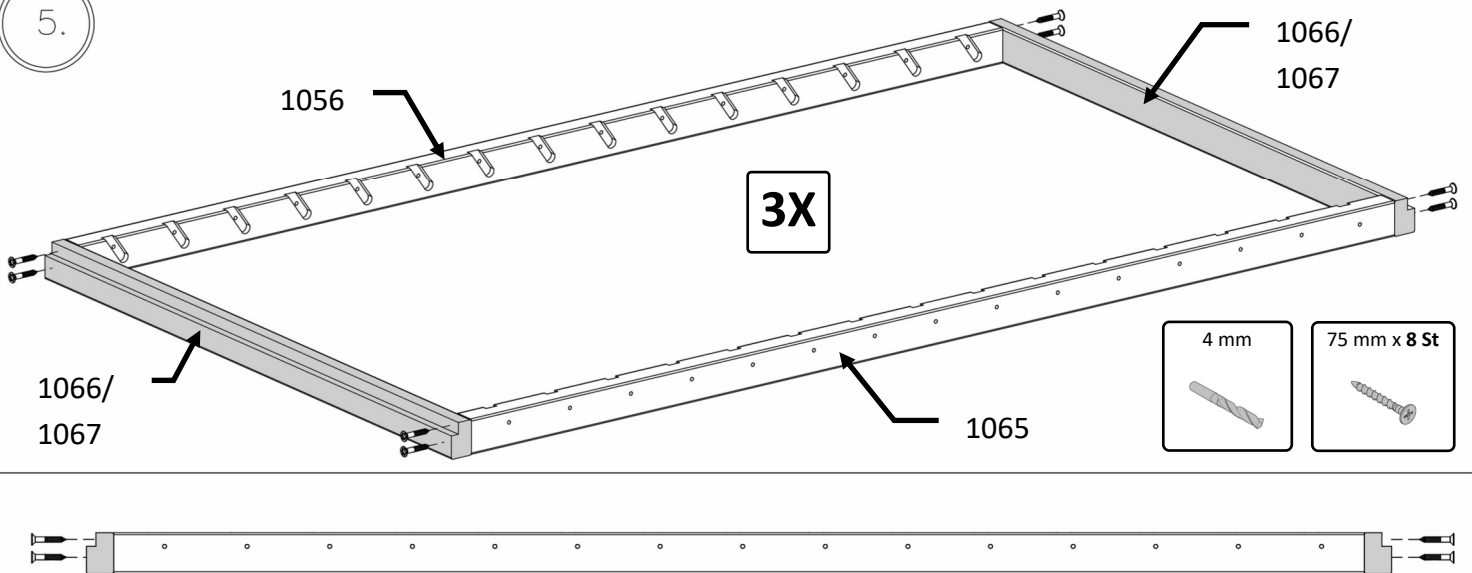

6.

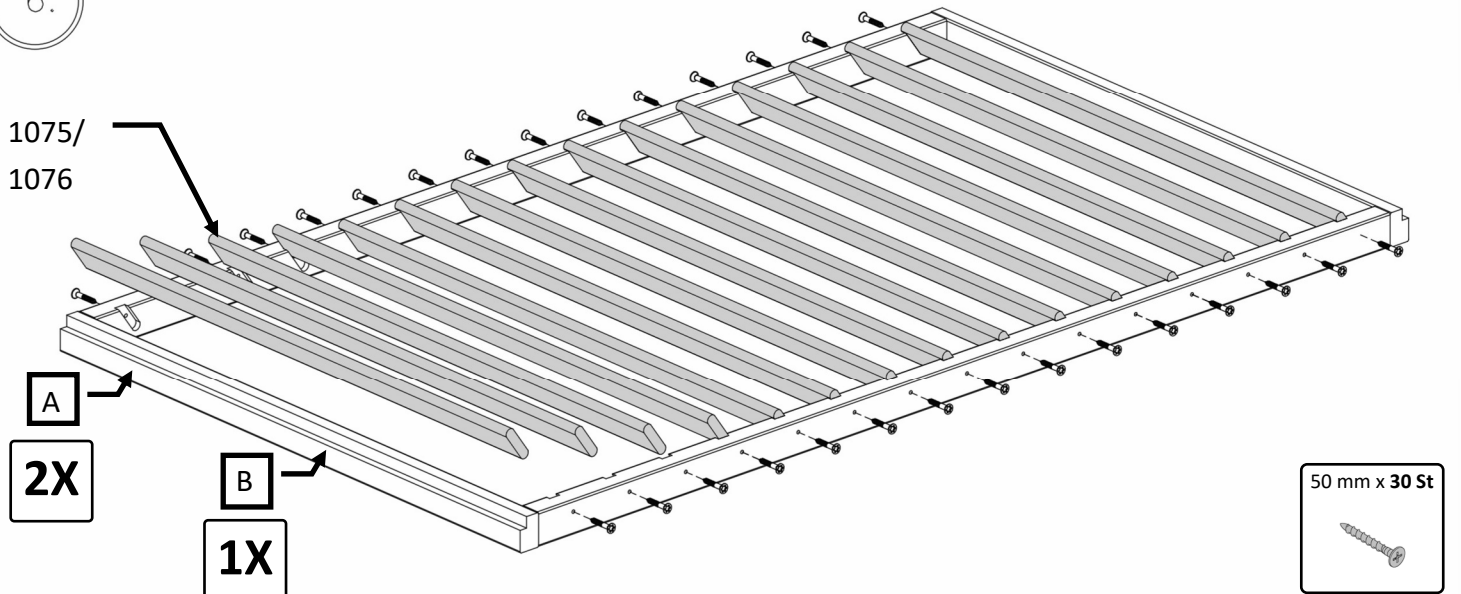

BCPUN1(NF)

7.

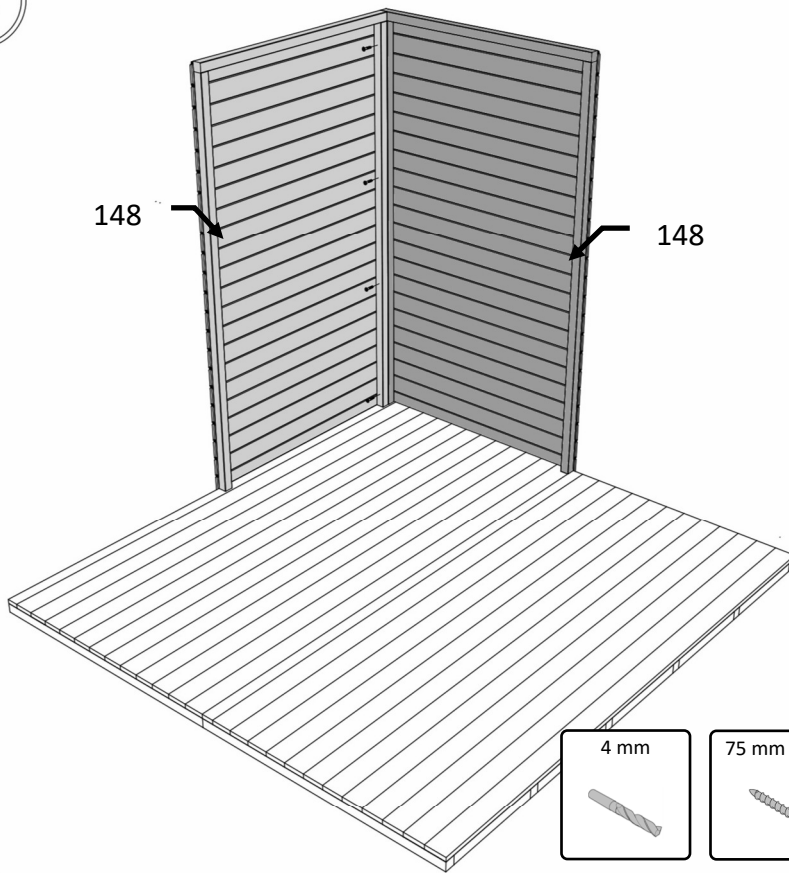

7.1

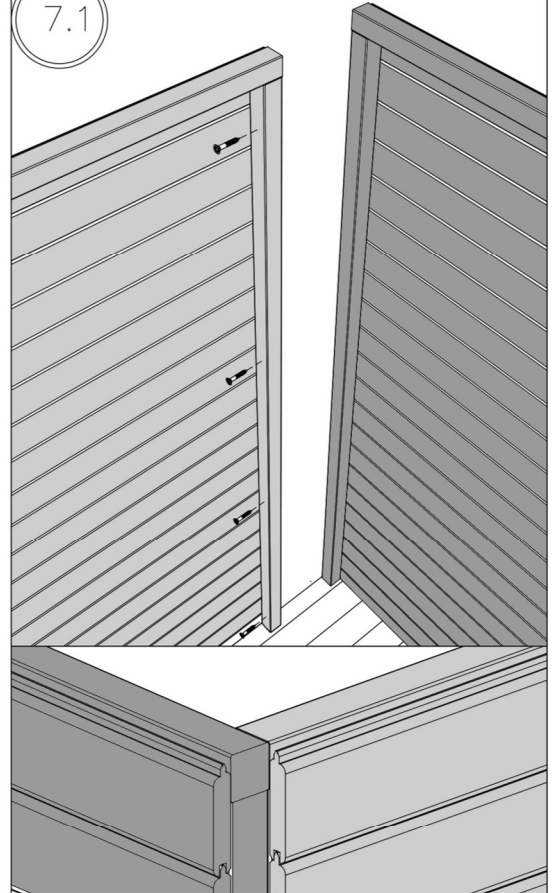

8.

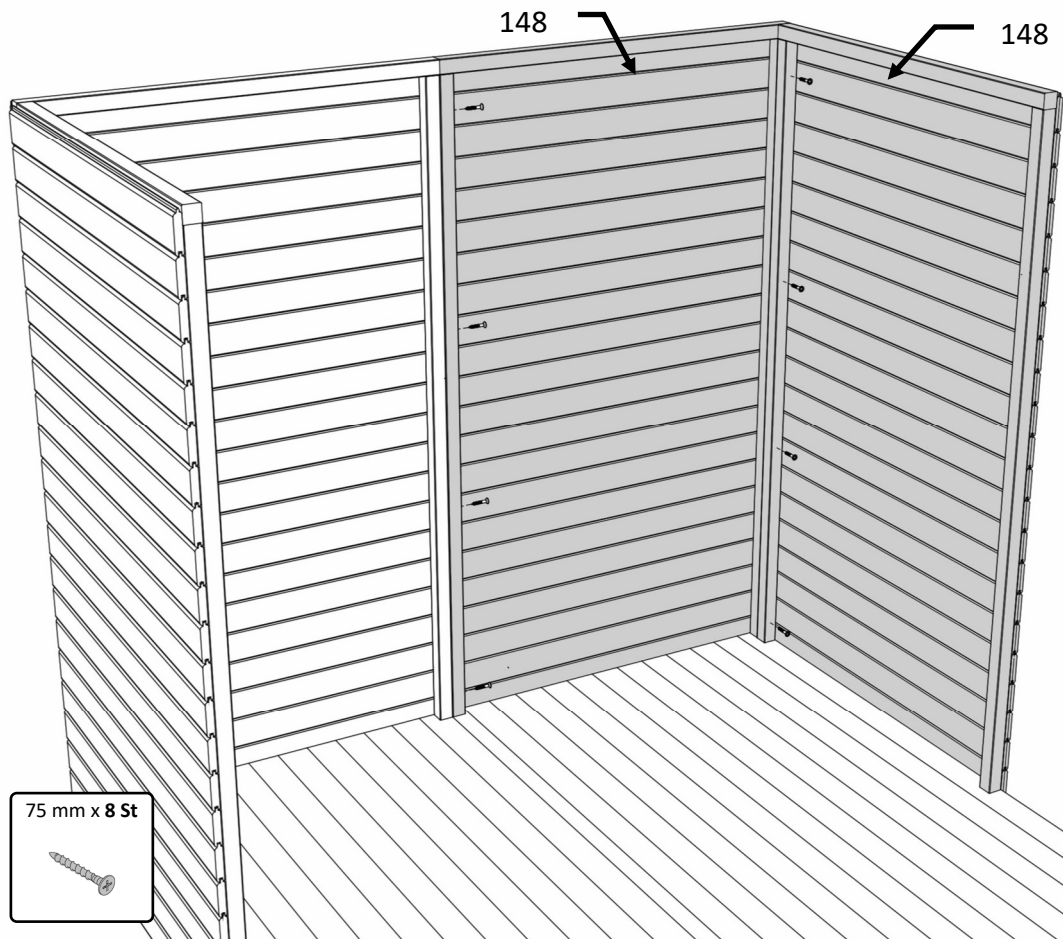

BCPUN1(NF)

9.

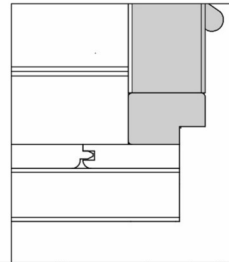
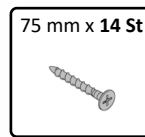
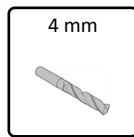
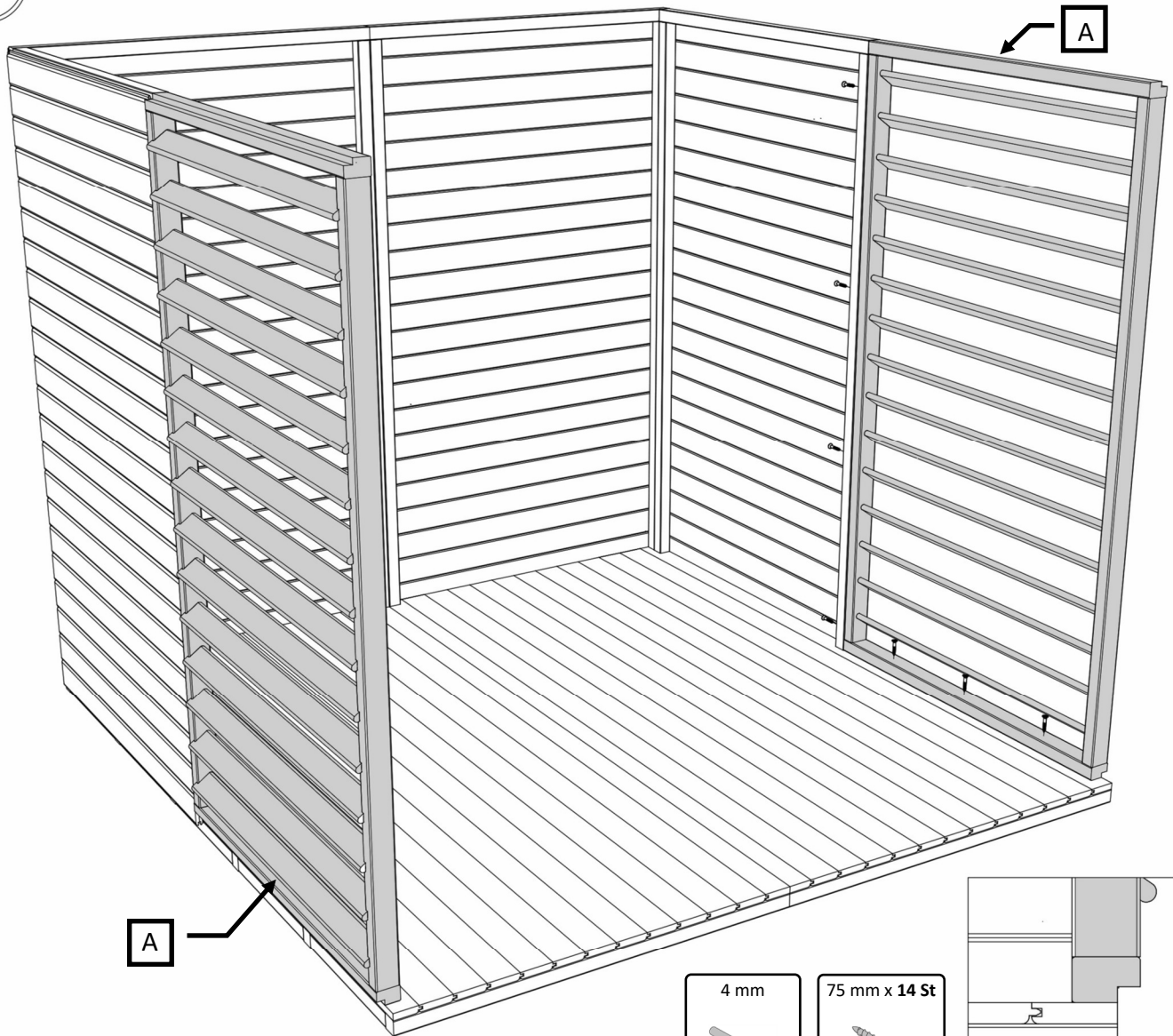

10.

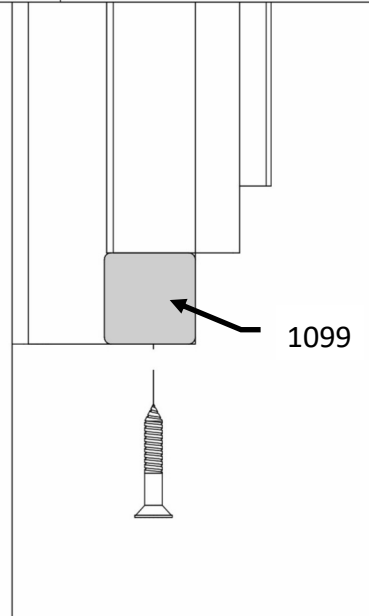
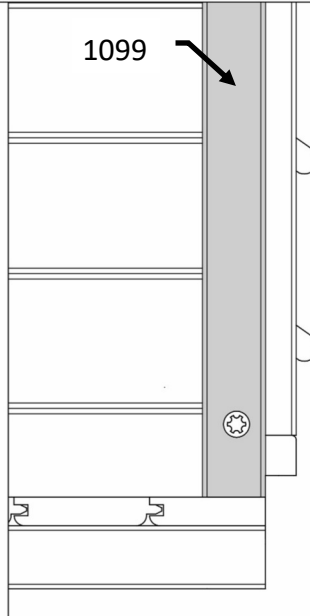
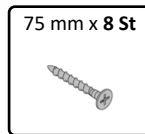
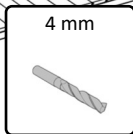
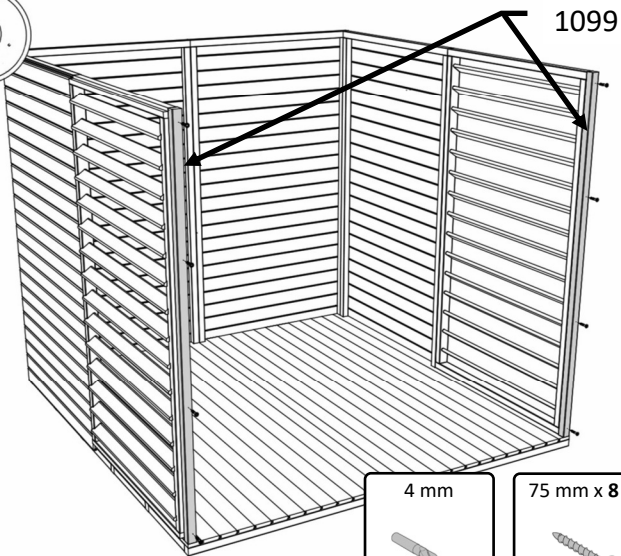

BCPUN1(NF)

11.

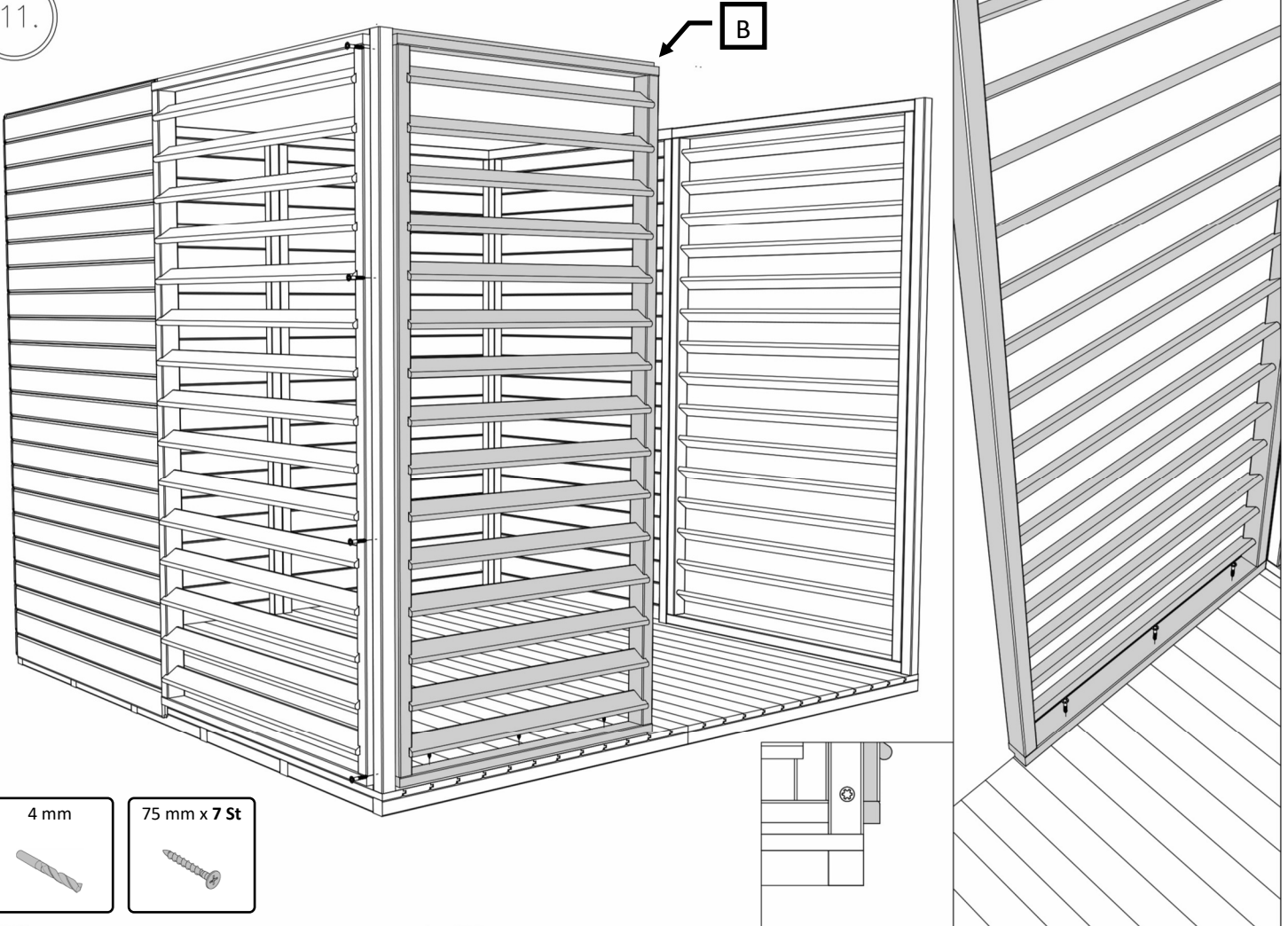

4 mm

75 mm x 7 St

12.

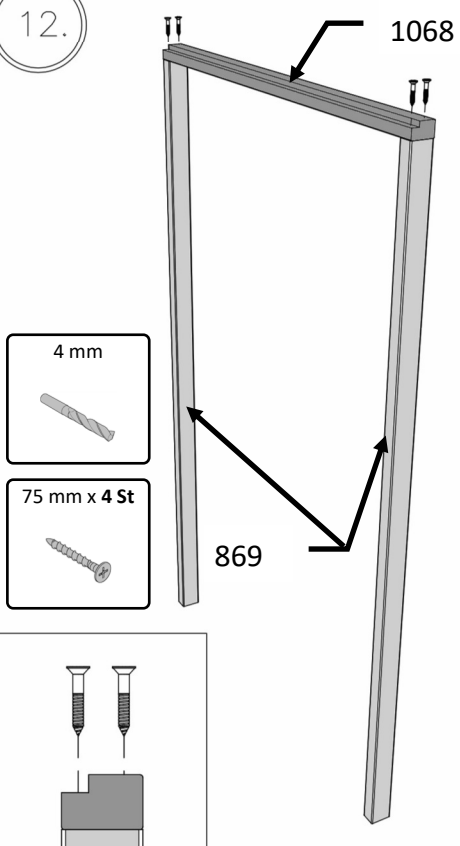

4 mm

75 mm x 4 St

869

1068

13.

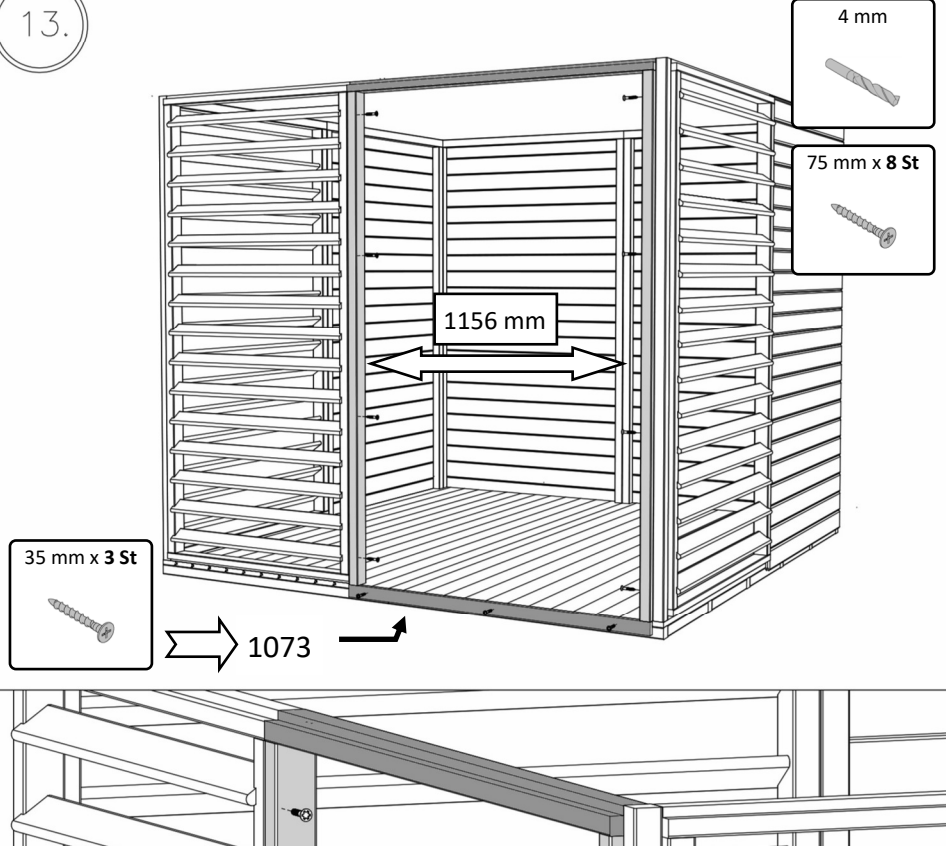

4 mm

75 mm x 8 St

35 mm x 3 St

1073

1156 mm

BCPUN1(NF)

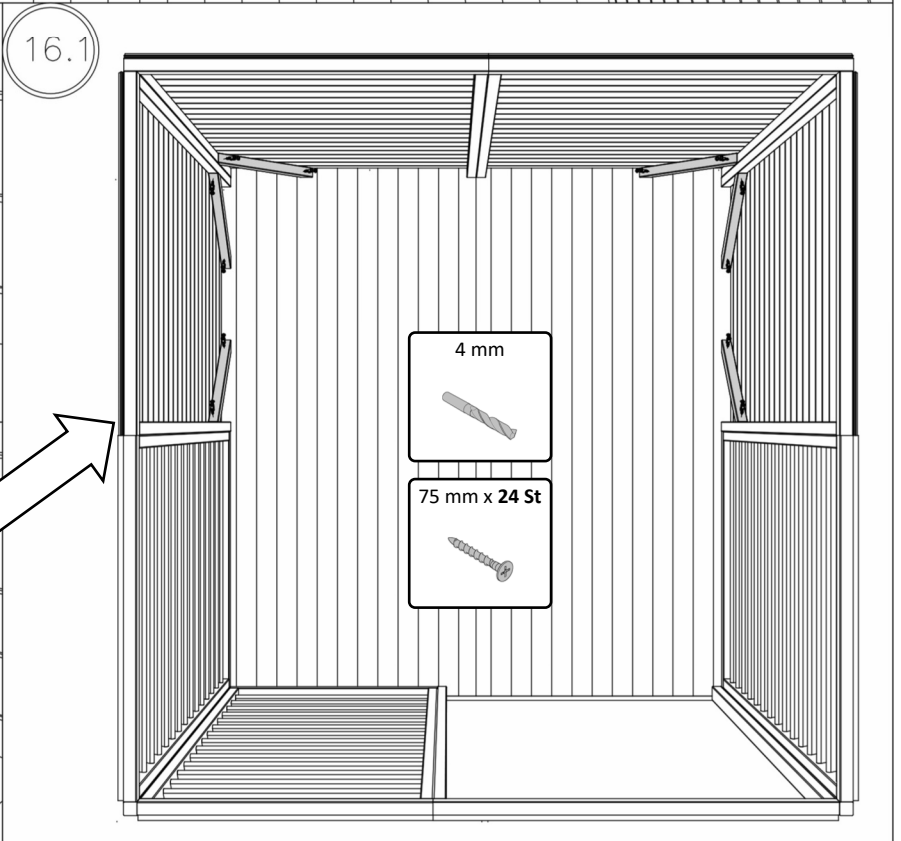
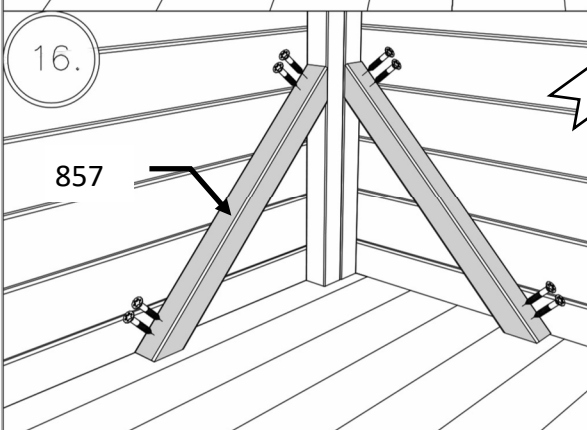
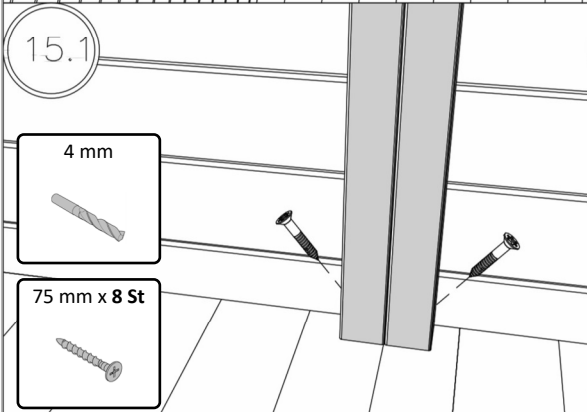
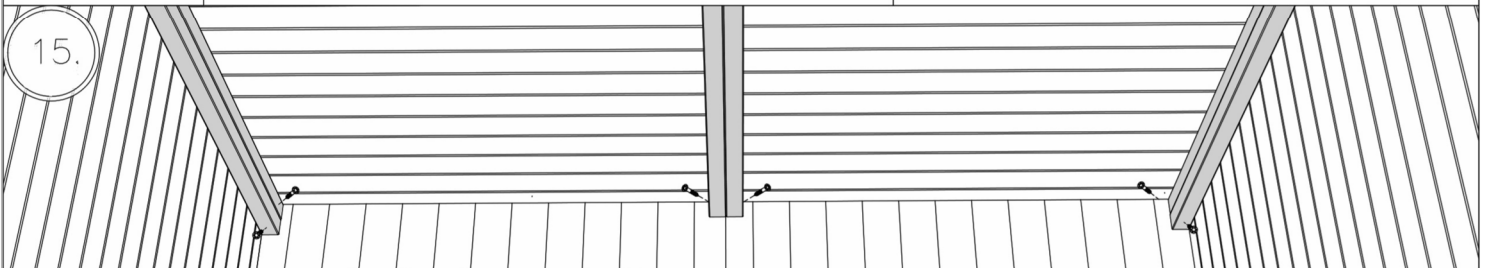
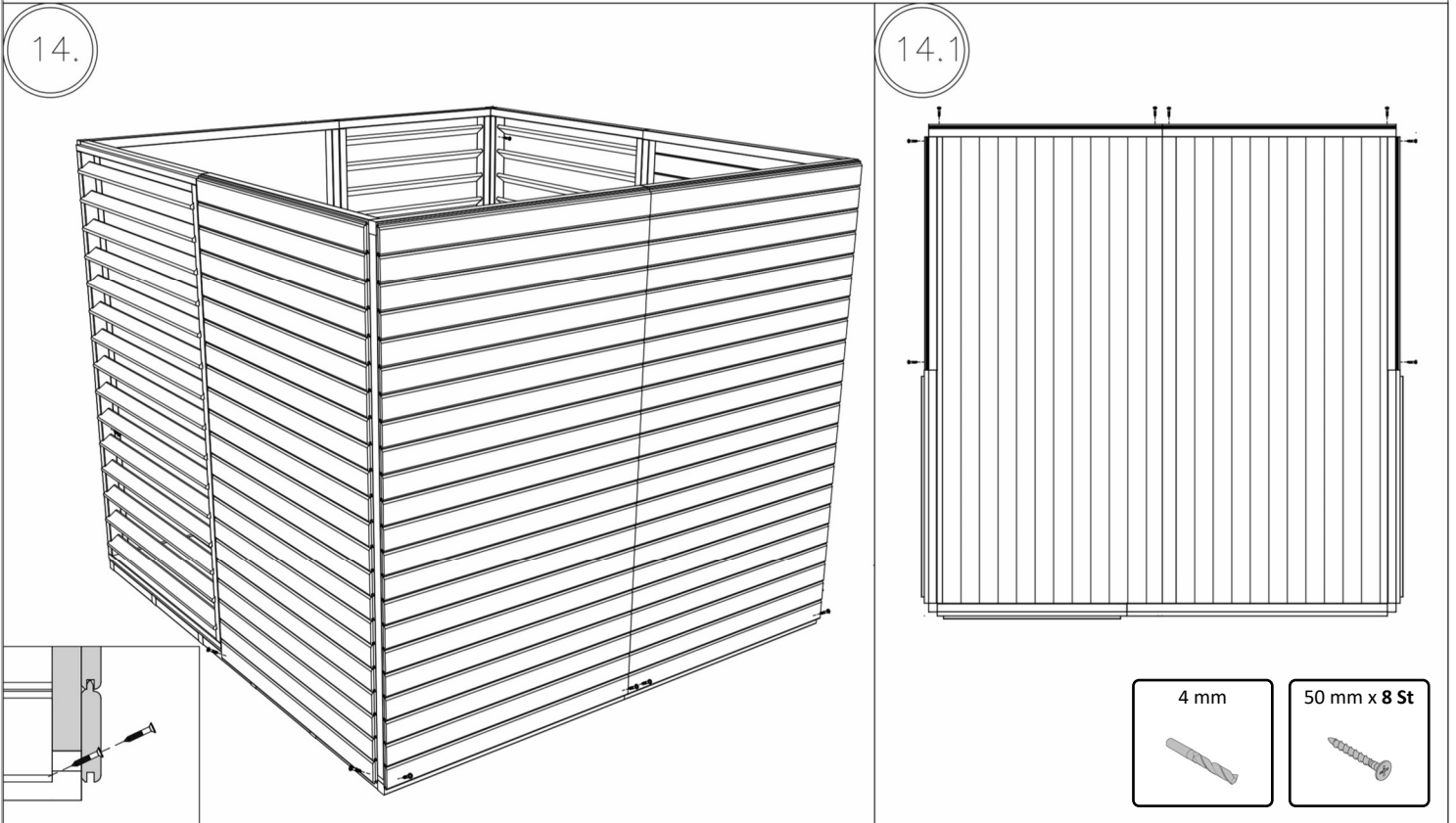

BCPUN1(NF)

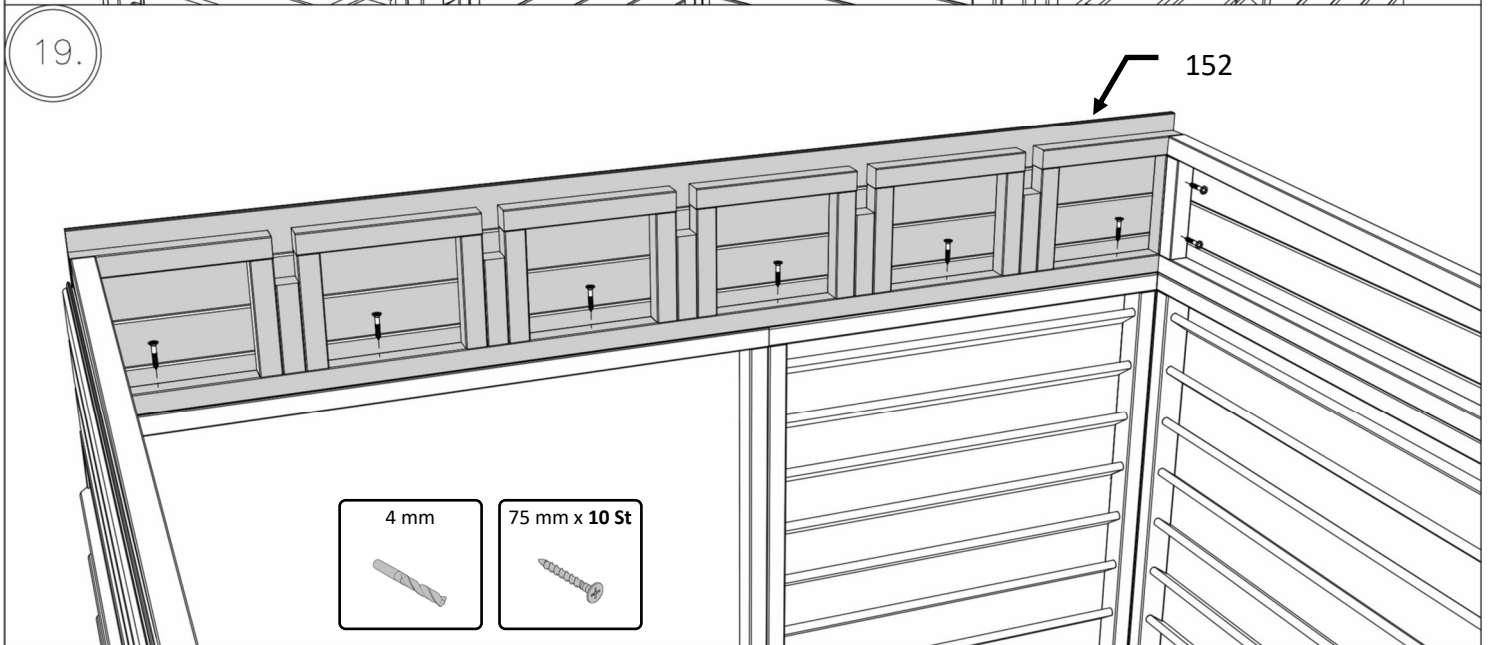
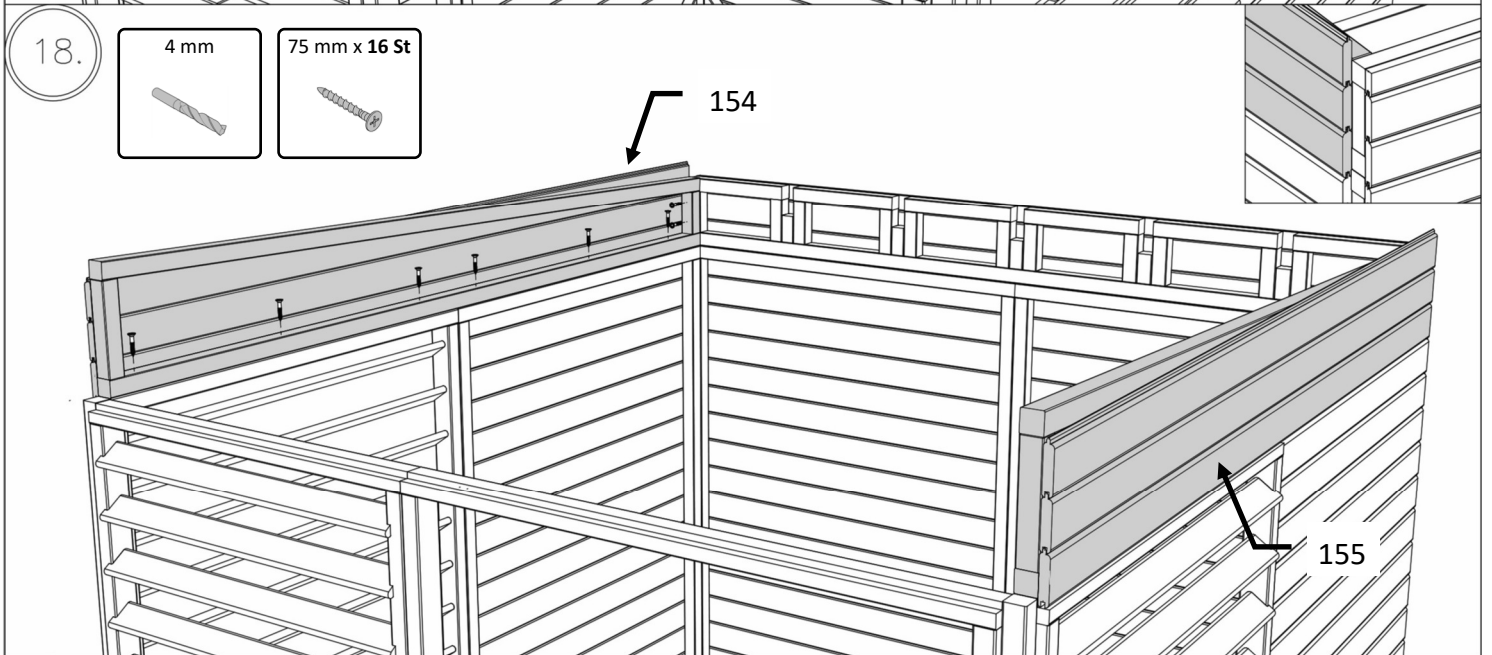
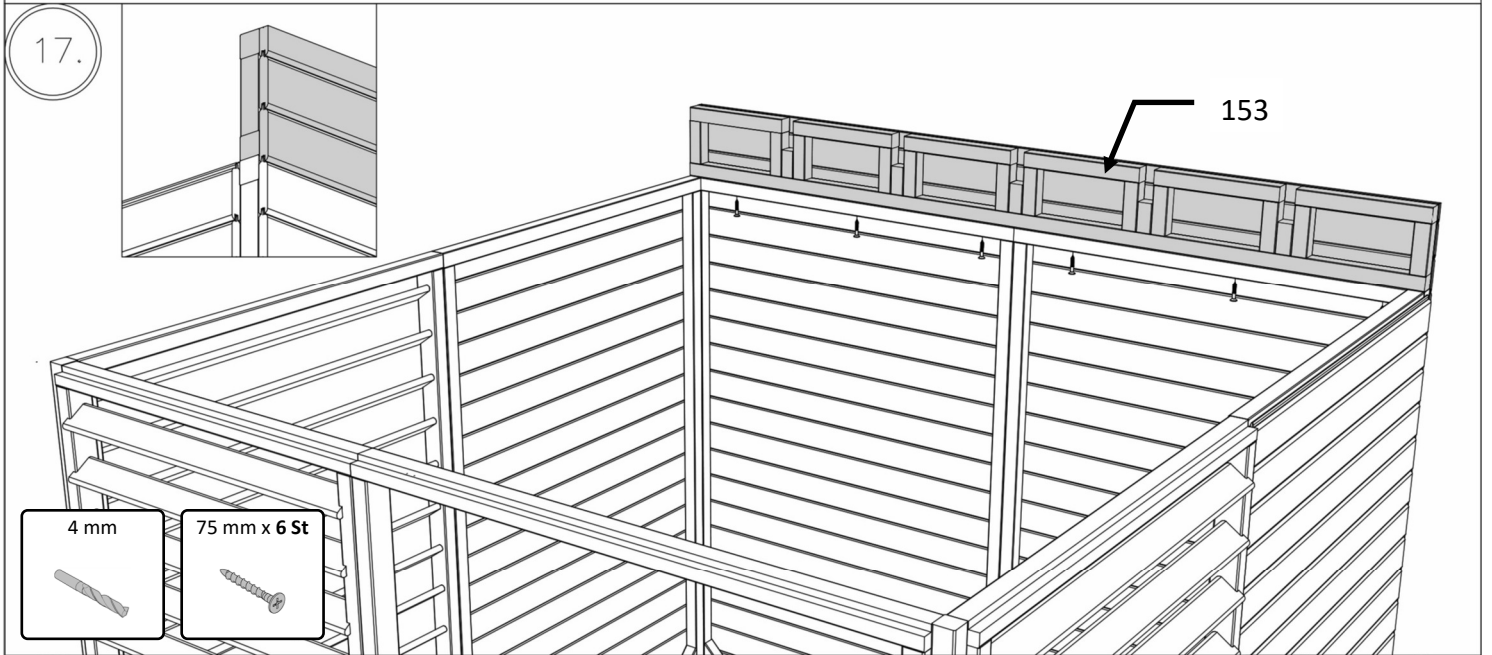

BCPUN1(NF)

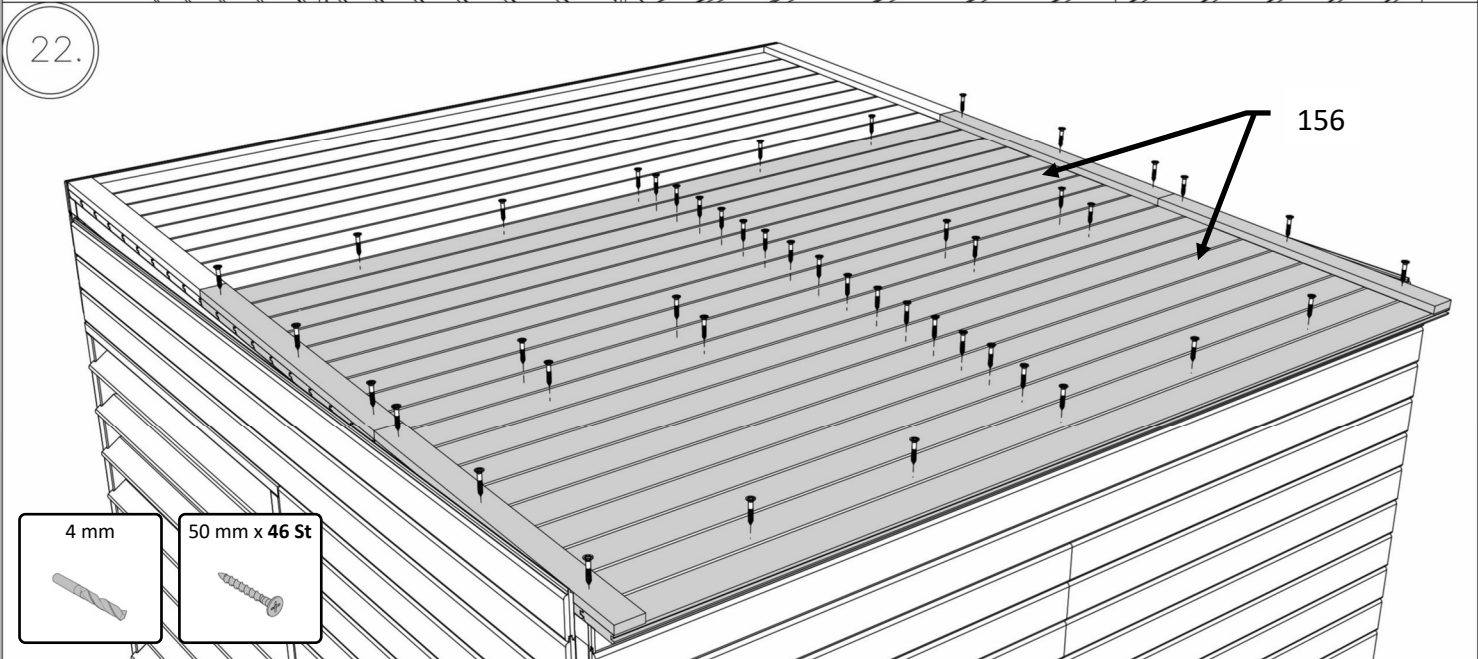
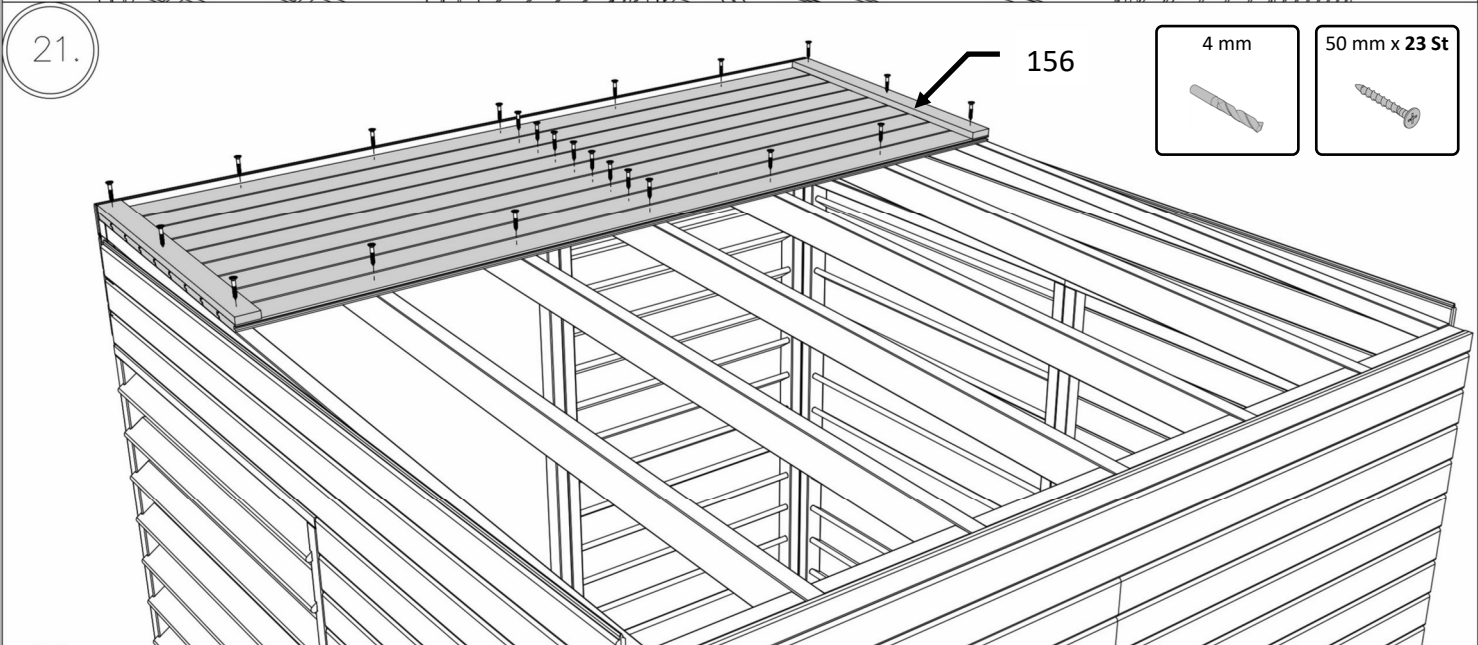
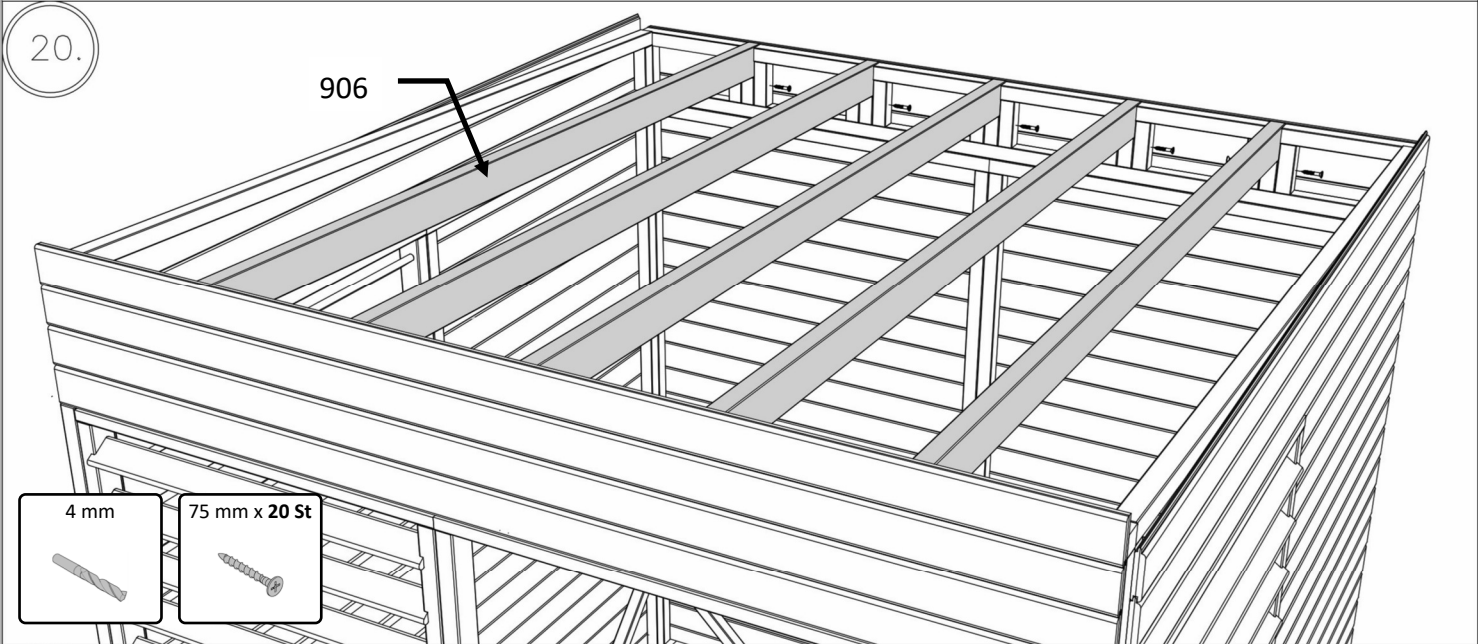

BCPUN1(NF)

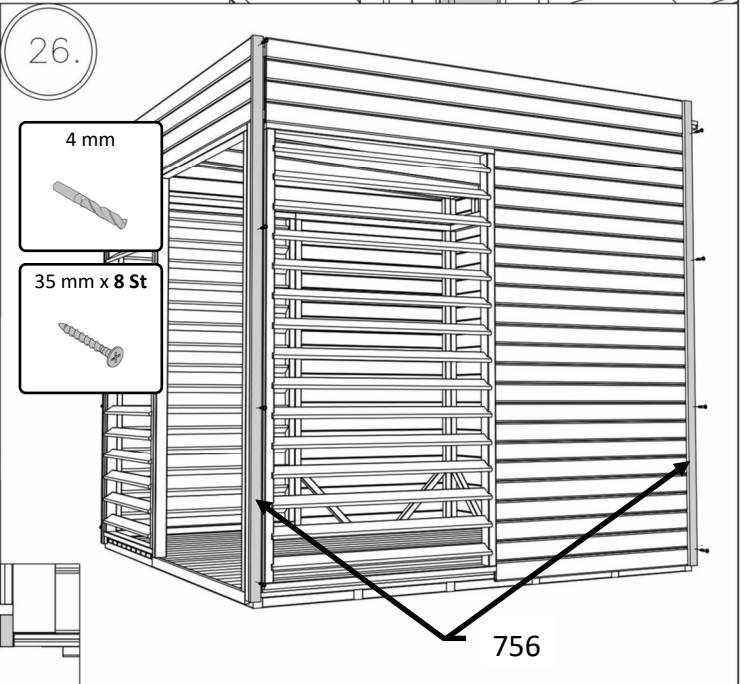
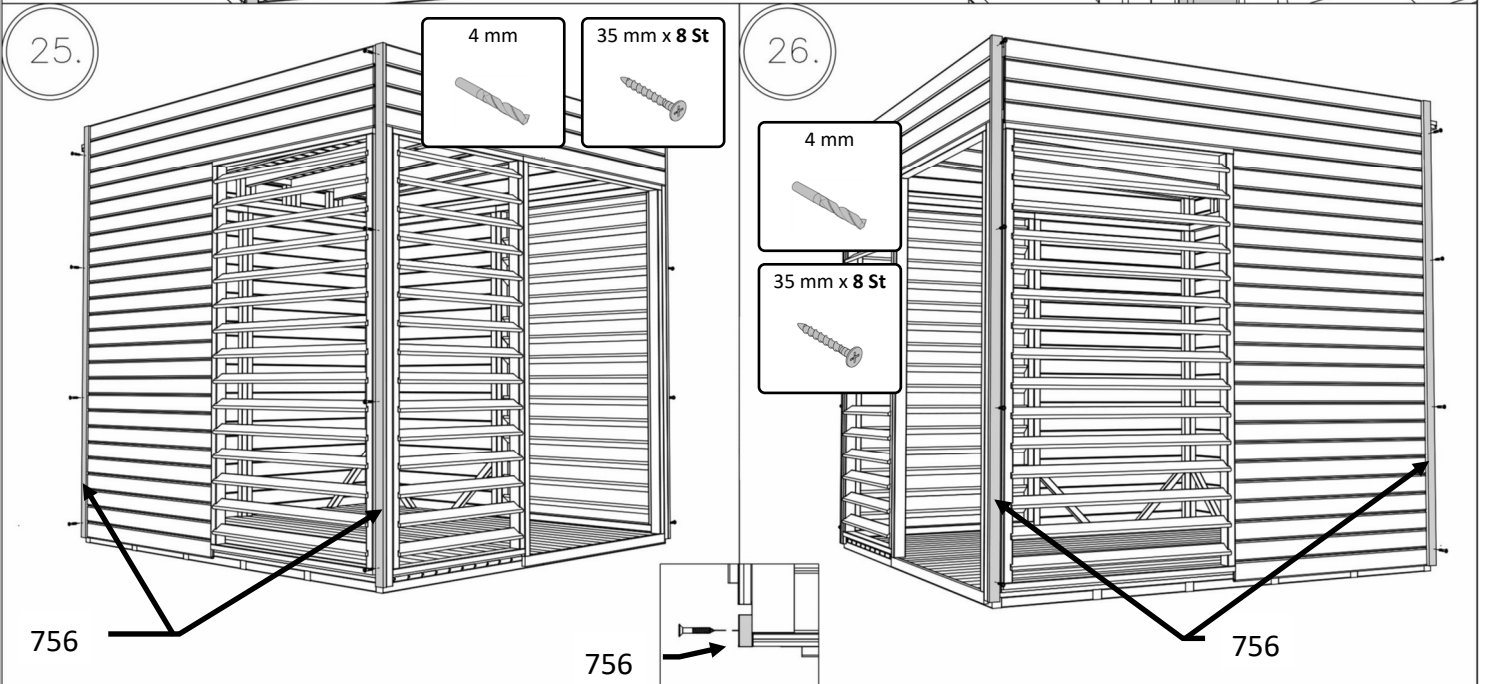
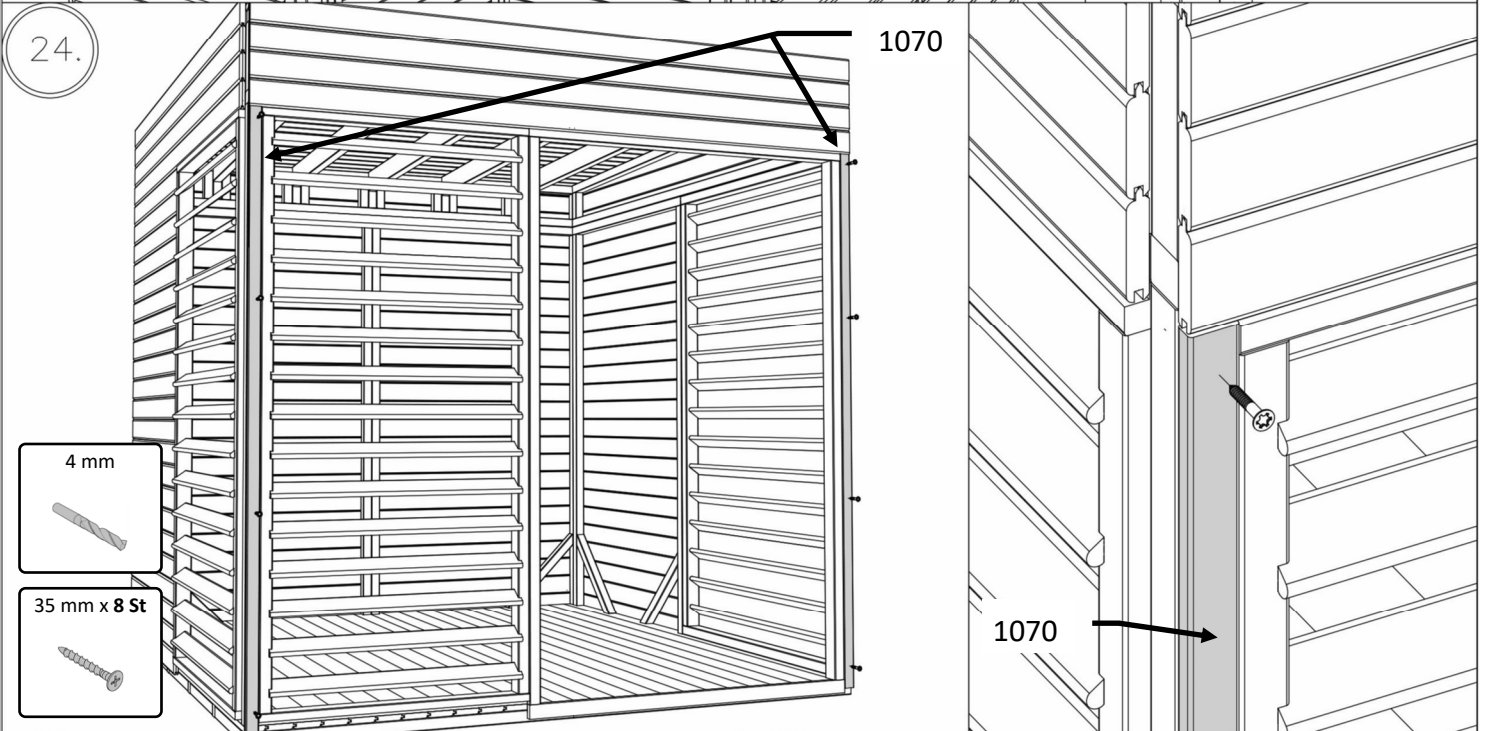
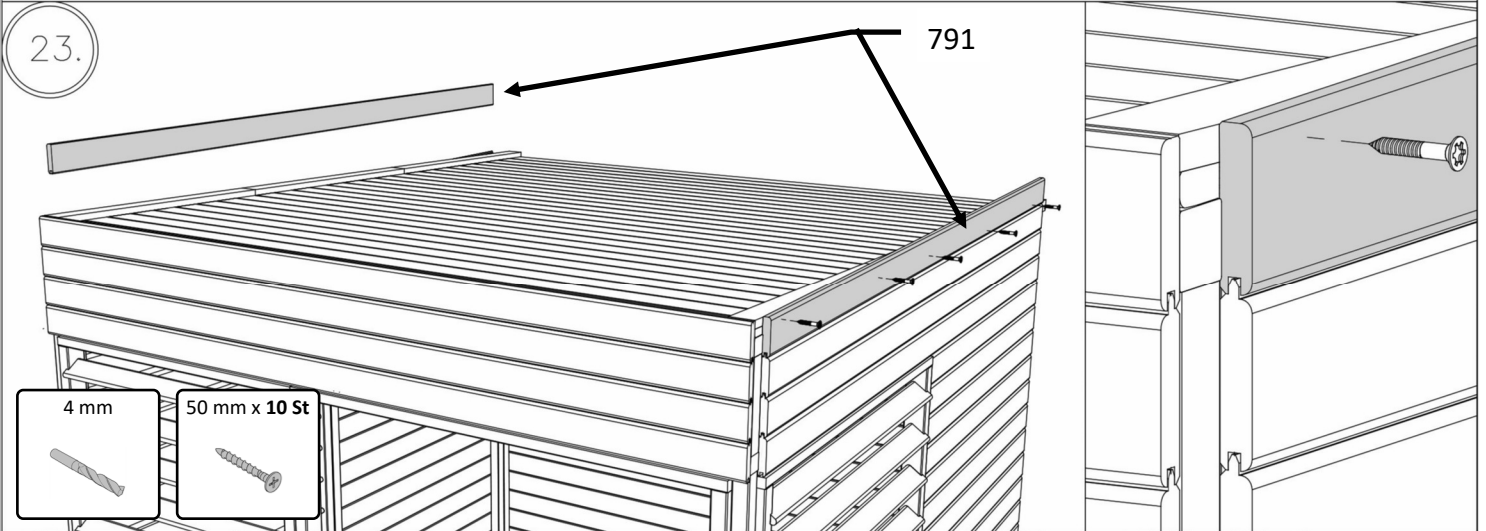

BCPUN1(NF)

27.

14 mm x 154 St

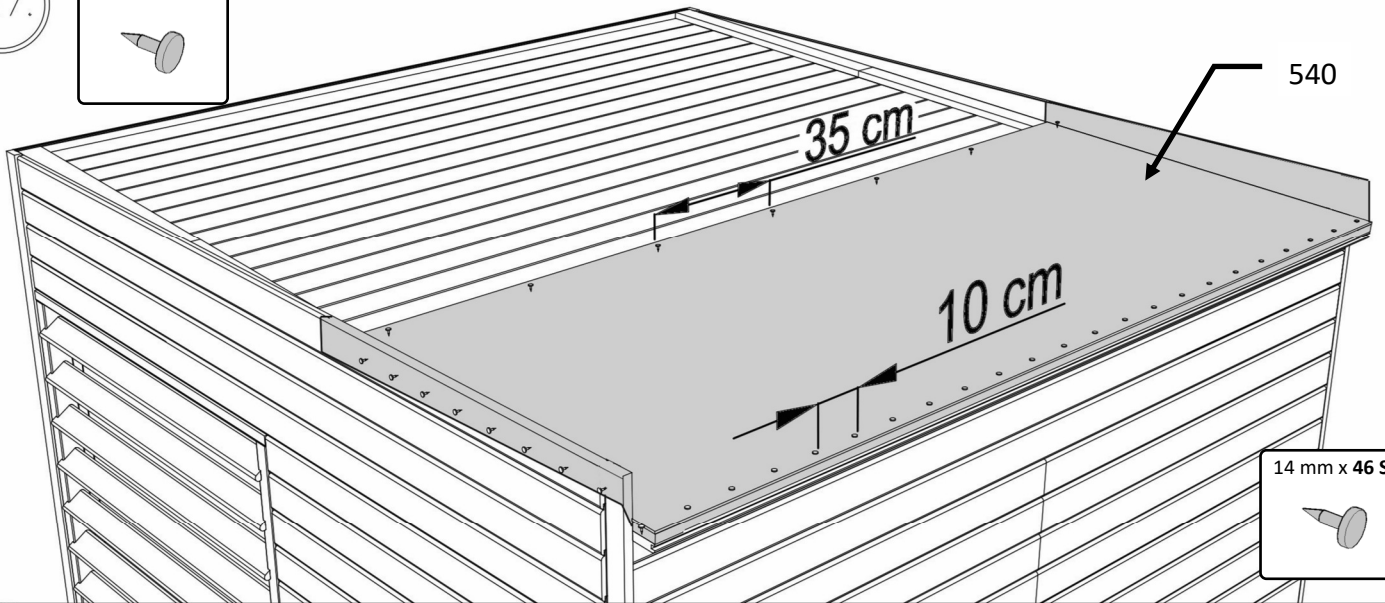

28.

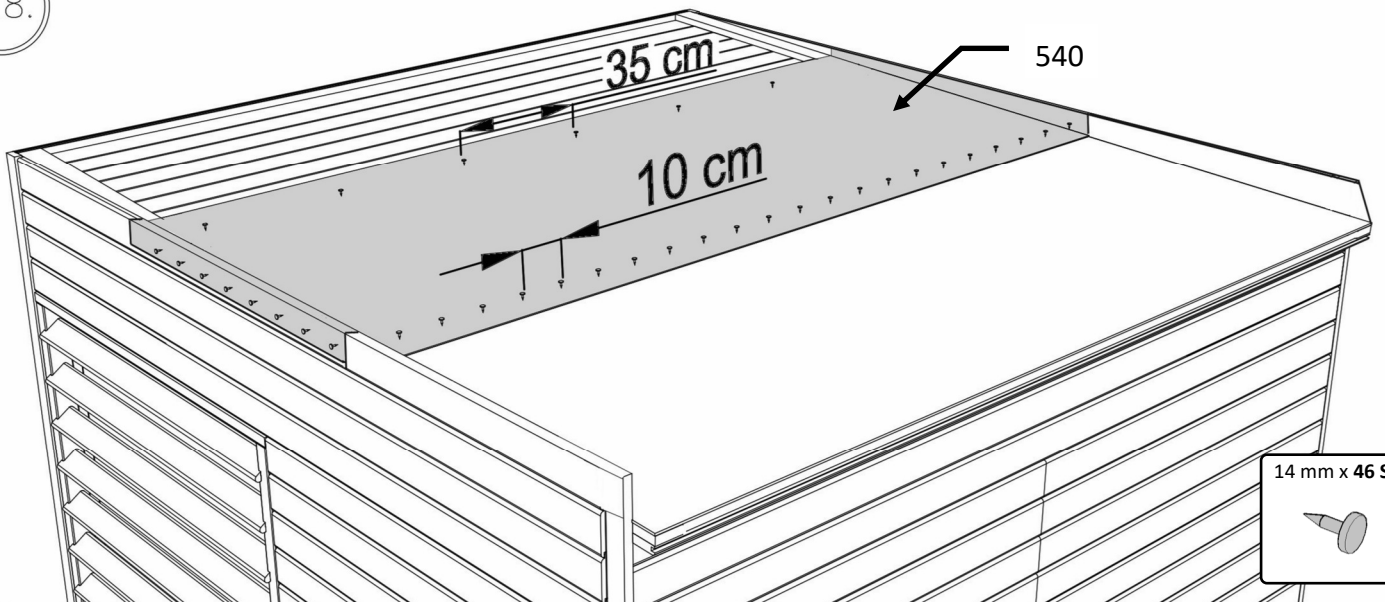

29.

540

10 cm

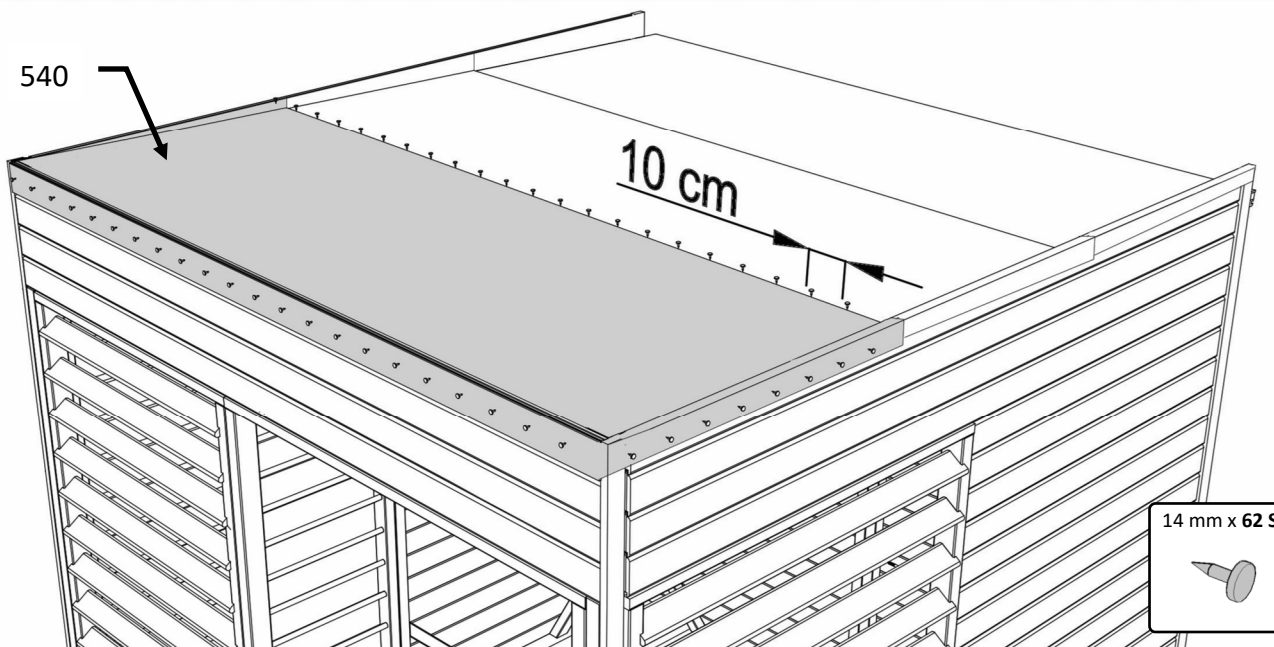

BCPUN1(NF)

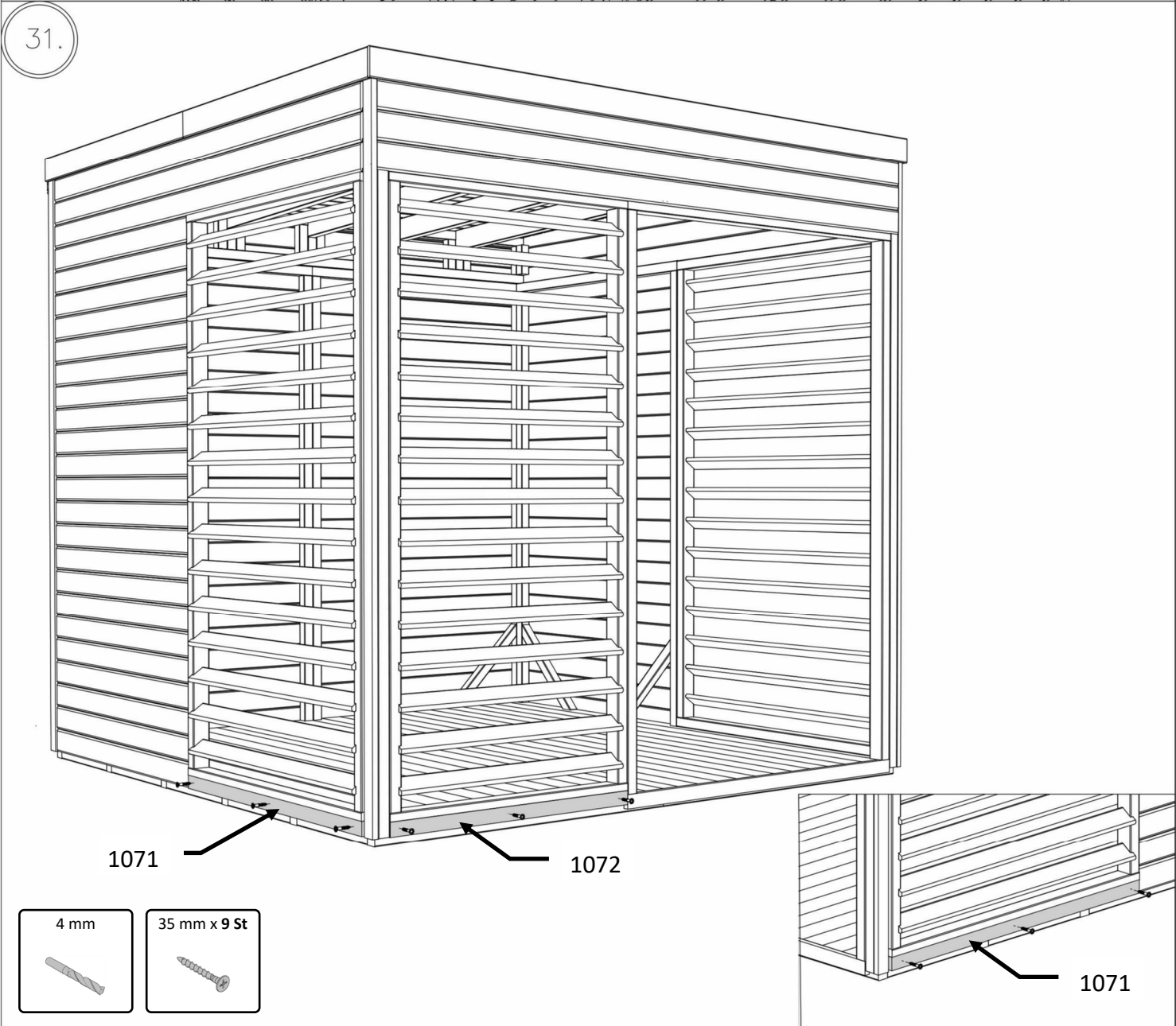
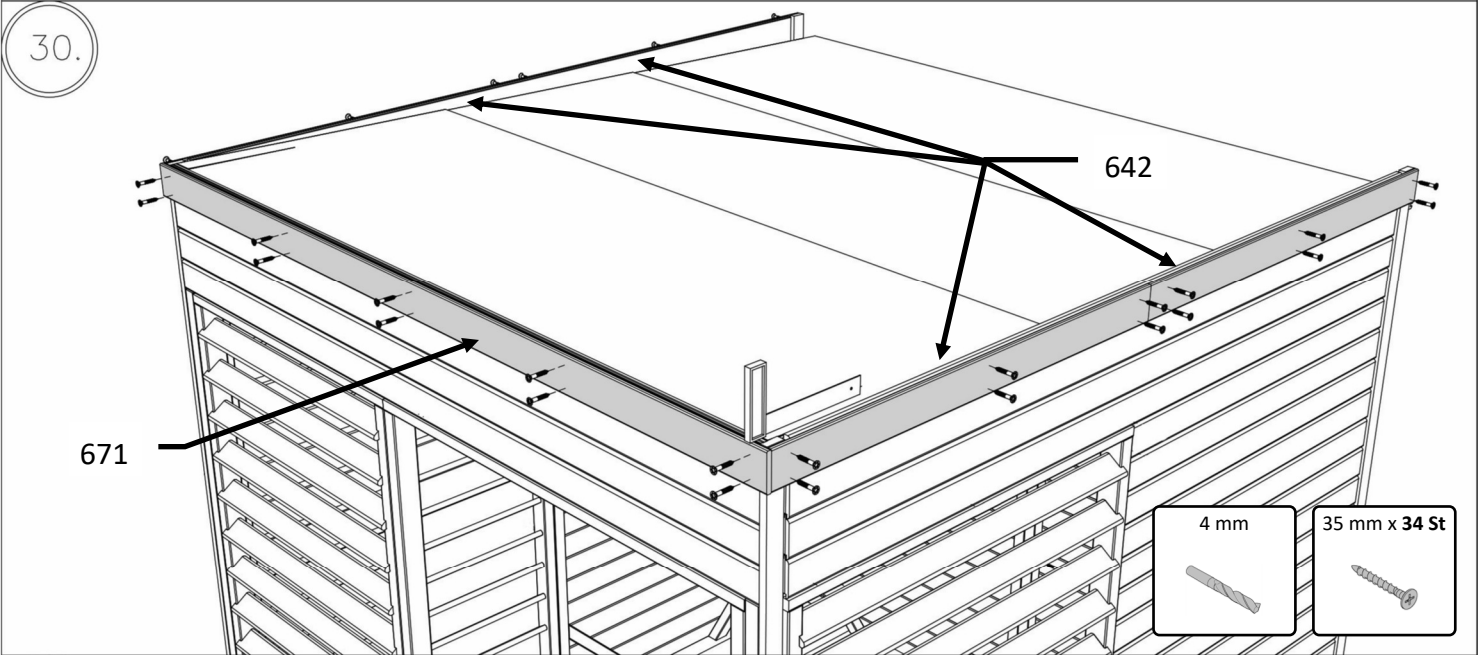

BCPUN1(NF)

32.

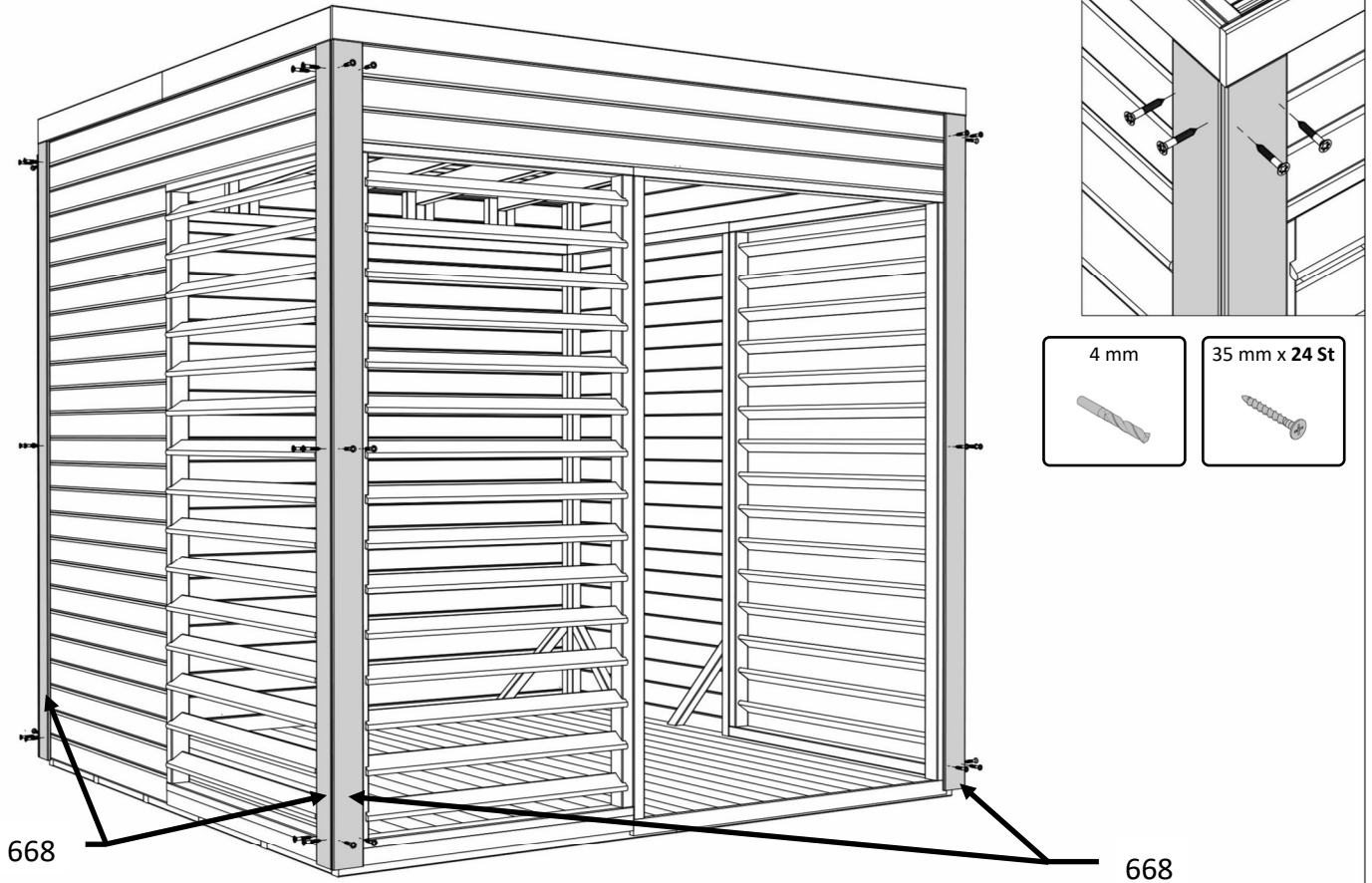

33.

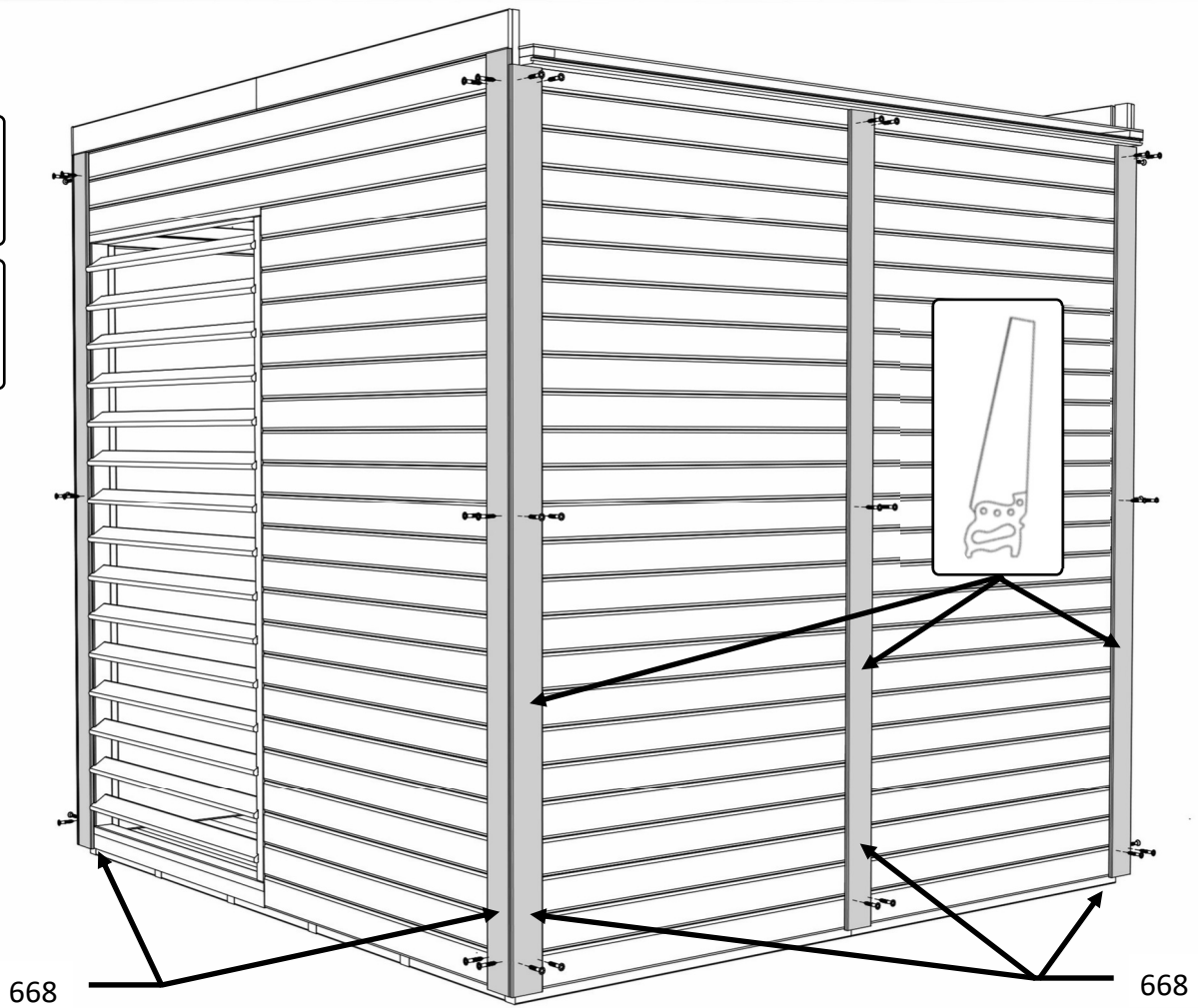
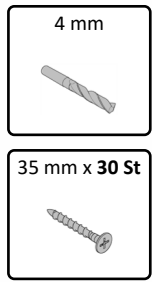

BCPUN1(NF)

34.

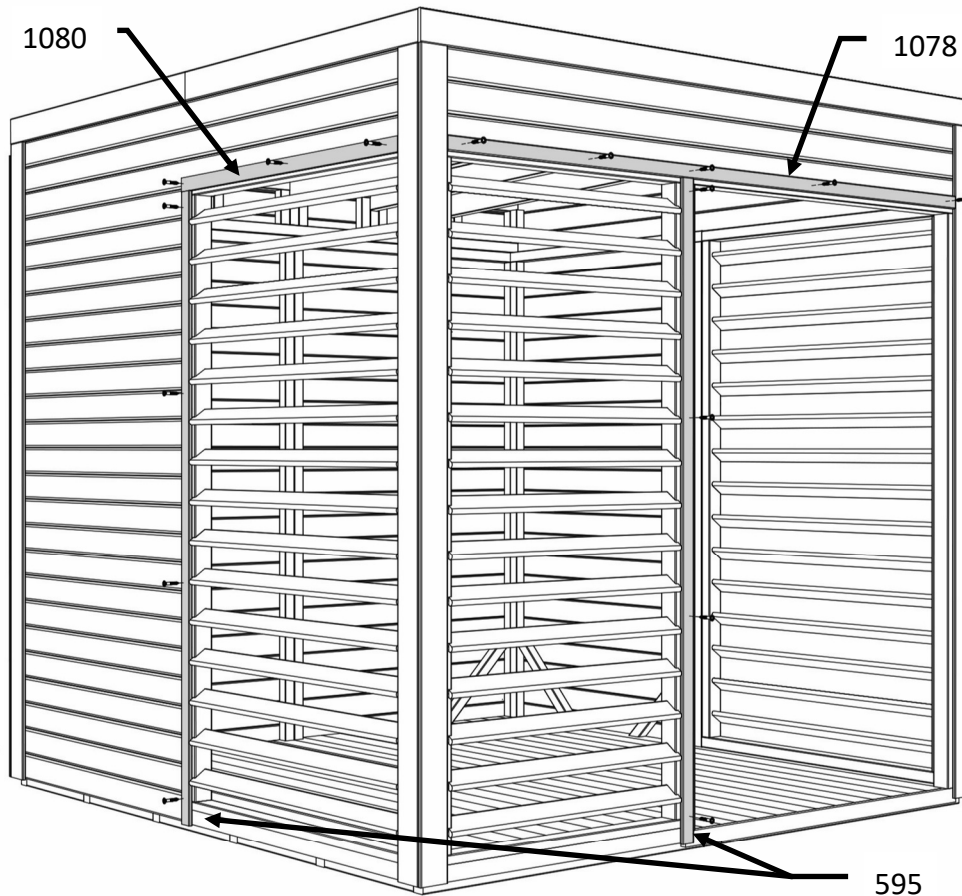

35 mm x 16 St



4 mm



35.

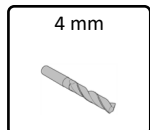

4 mm



35 mm x 7 St

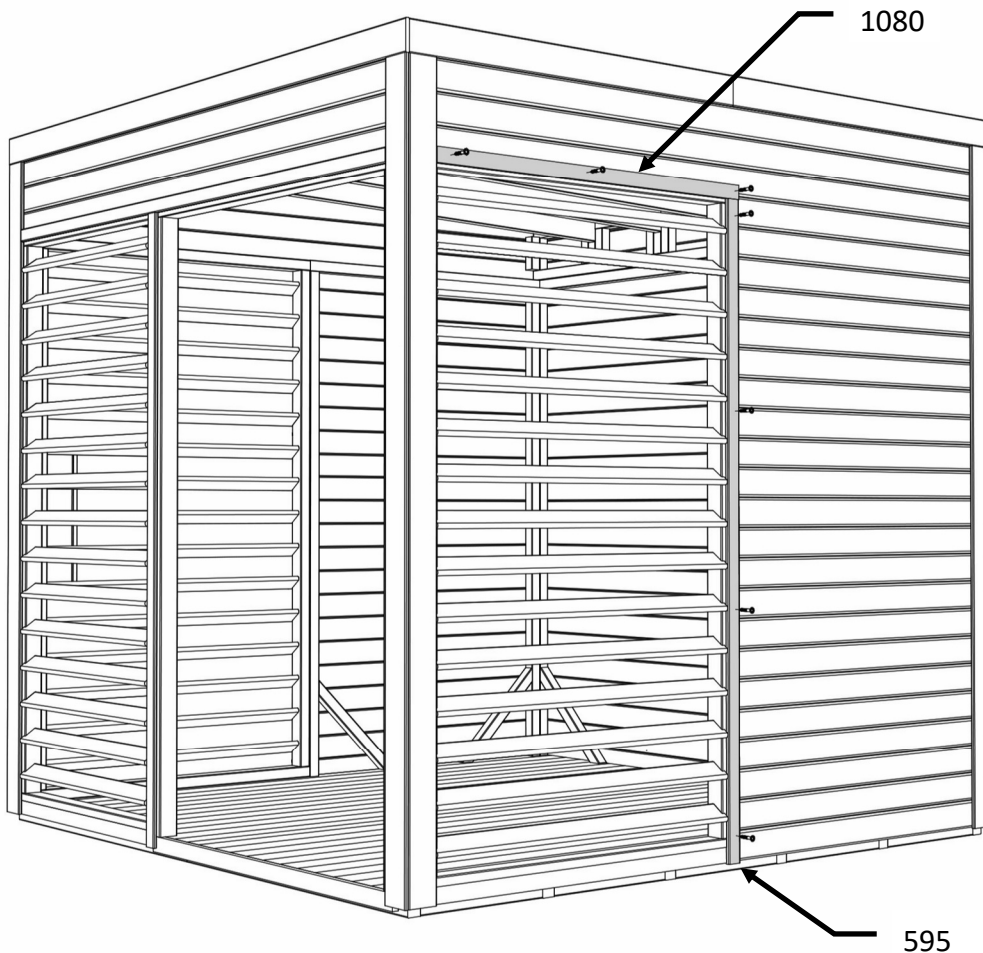

595