

PRP6x8

V.3

Aufbauanleitung

DE - Bevor Sie beginnen:

- Es ist empfehlenswert sich etwas Zeit zu nehmen, um die Aufbauanleitung zu lesen, bevor mit dem Aufbau begonnen wird.
- Der Aufbau sollte in der vorgegebenen Reihenfolge erfolgen.
- Die Aufbauanleitung dient lediglich als Richtschnur für den Aufbau. Nicht alle Schritte sind im Detail vorgegeben.
- Bitte prüfen Sie alle Teile auf Vollständigkeit und Zustand vor dem Aufbau. Der Aufbau sollte durch mindestens 2 Personen erfolgen.
- Bei starkem Wind sollte der Aufbau nicht erfolgen.
- Bohren Sie die Teile vor, wo es angezeigt wird.
- Wir empfehlen, das Gerätehaus erst nach weitgehendem Aufbau vor Anbringung der Deckleisten mit Farbe oder Holzlasur zu behandeln, da sich die Elemente bei einer einseitigen Behandlung verziehen können, wodurch der Aufbau erschwert werden könnte.

I

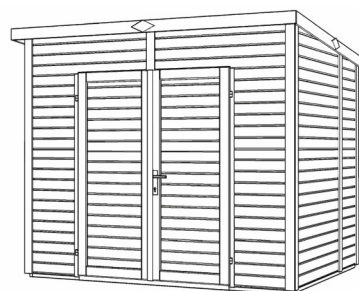

Instructions d'assemblage

FR - Avant de commencer:

- Avant de commencer le processus d'assemblage, veuillez s'il vous plaît vous familiariser parfaitement avec les instructions.
- La maison doit être assemblée suivant la séquence indiquée dans les instructions.
- Les instructions s'entendent comme lignes directrices, toutes les étapes ne sont pas décrites en détails.
- Avant de commencer l'assemblage, vérifiez tous les éléments.
- Deux personnes sont nécessaires au minimum pour l'assemblage.
- Ne pas tenter d'assembler la maison dans des conditions de vents forts.
- Percer les trous dans les éléments suivant les marques.

II

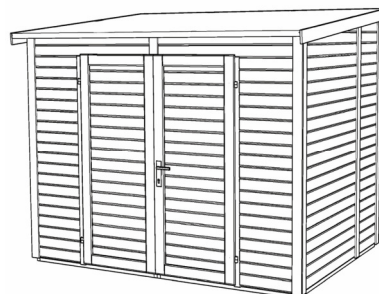

Montage-instructie

NL - Alvorens te beginnen:

- Voordat u begint met de montage raden wij u aan de handleiding grondig door te lezen.
- Bij de montage van het huis dient u de volgorde zoals deze in de handleiding is aangegeven te volgen.
- De handleiding is bedoeld als richtsnoer, niet alle stappen zijn in detail uitgewerkt.
- Vóór de montage dienen alle details gecontroleerd te worden.
- De montage van het huis dient door tenminste twee personen uitgevoerd te worden.
- Het huis nooit in harde wind opbouwen.
- Gaten in onderdelen boren, waar dit staat aangegeven.

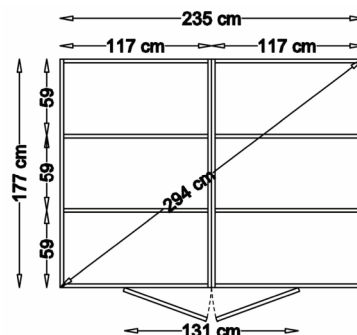

Pokyny k montáži

CZ - Než začnete:

- Než začnete s montáží, seznámte se důkladně s těmito pokyny.
- Domek musí být sestaven v pořadí uvedeném v pokynech.
- Pokyny slouží pouze jako vodítko, ne všechny kroky jsou zde popsány dopodrobna.
- Než začnete s montáží, zkontrolujte všechny díly.
- K montáži jsou zapotřebí minimálně dvě osoby.
- Nepokoušejte se smontovat domek za silného větru.
- Vyvrtejte do dílů otvory podle značek.

Pokyny pre montáž

SK - Predtým, než začnete:

- Predtým, než začnete montovať, sa, prosím, dôkladne oboznámte s týmito pokynmi.
- Dom je potrebné zmontovať podľa poradia uvedeného v pokynoch.
- Tieto pokyny poskytujú návod, nepopisujú však detailne všetky kroky.
- Predtým, než začnete montovať, skontrolujte všetky časti.
- Pri montáži sú potrební najmenej dvaja ľudia.
- Nepokúšajte sa montovať dom pri silnom vetre.
- Otvory v jednotlivých častiach vyvrtajte podľa označenia.



PRP6x8

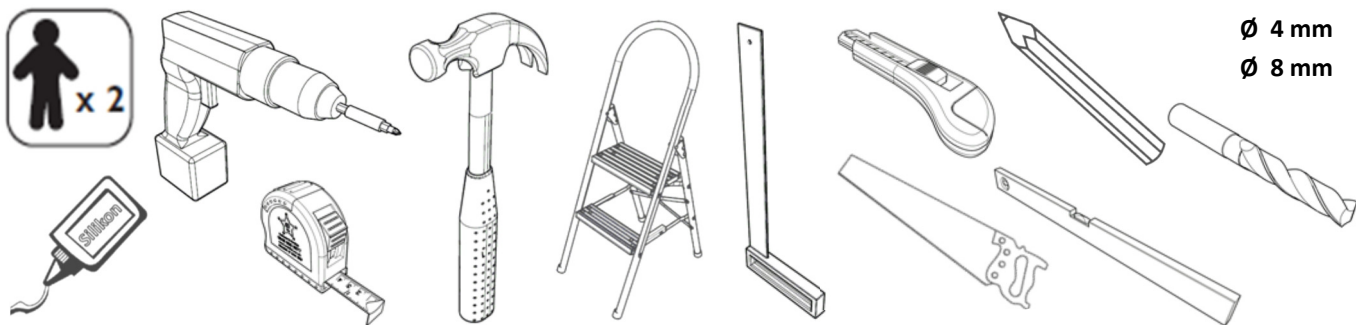

Ø 4 mm
Ø 8 mm

Pos.	Details in cm	Pcs.
1.	35 x 170	1
2.	35 x 117	1
3.	117 x 170	2
4.	52 x 117	1
5.	35 x 117	1
6.	65 x 169	1
7.	65 x 169	1

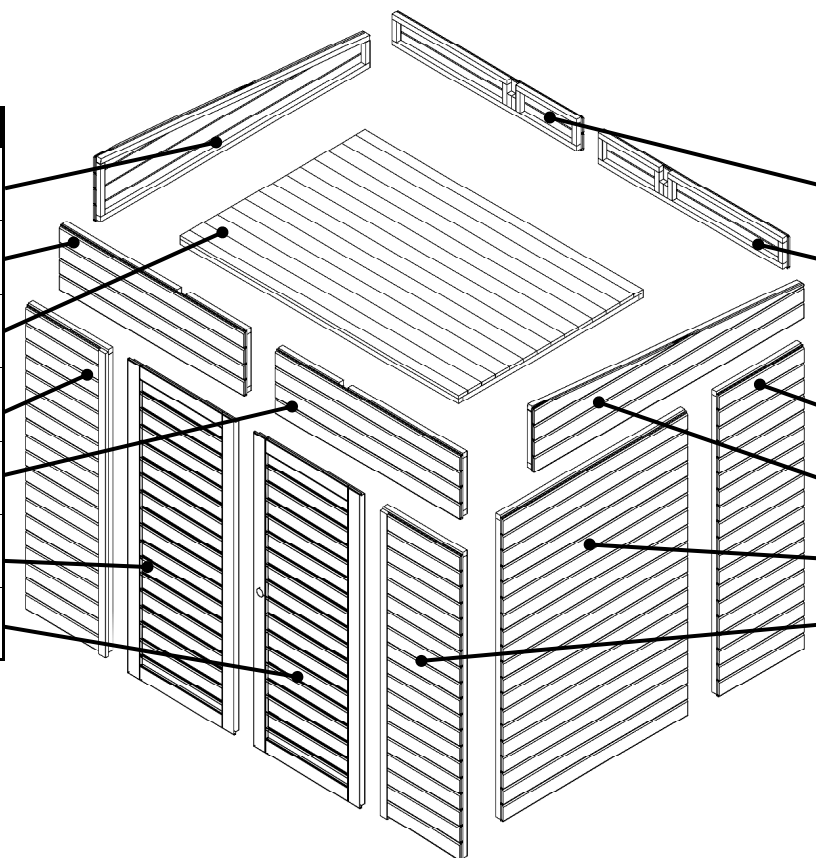

Pos.	Details in cm	Pcs.
8.	18 x 117	1
9.	18 x 117	1
11.	52 x 170	2
12.	35 x 170	1
13.	117 x 170	4
14.	52 x 117	1

PRP6x8

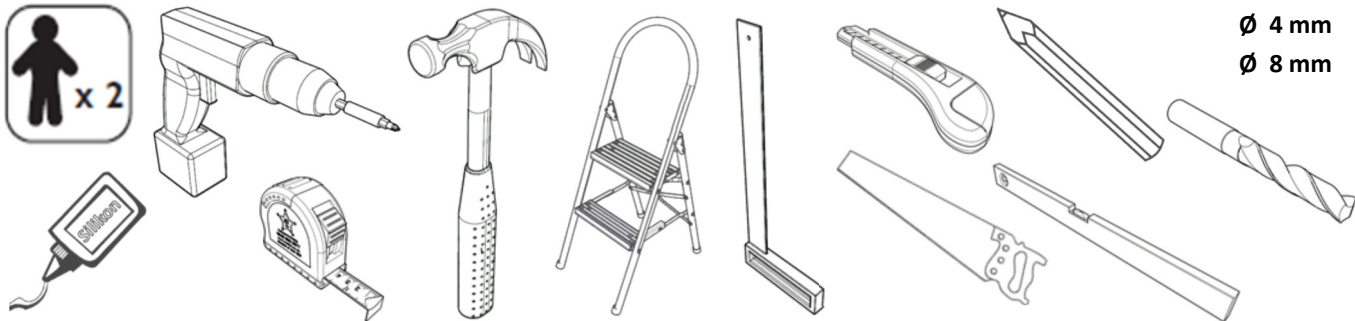

Ø 4 mm
Ø 8 mm

Pos.	Details in cm	Pcs.
15.	1,9 x 4,5 x 36	2
16.	1,9 x 4,5 x 18	2
17.	1,2 x 7 x 36	7
18.	1,2 x 7 x 18	5
19.	1,2 x 7 x 168	11
20.	1,9 x 4,5 x 168	4
21.	1,2 x 4,2 x 168	3
25.	2,8 x 2,8 x 133	1
26.	1,9 x 4,2 x 133	1

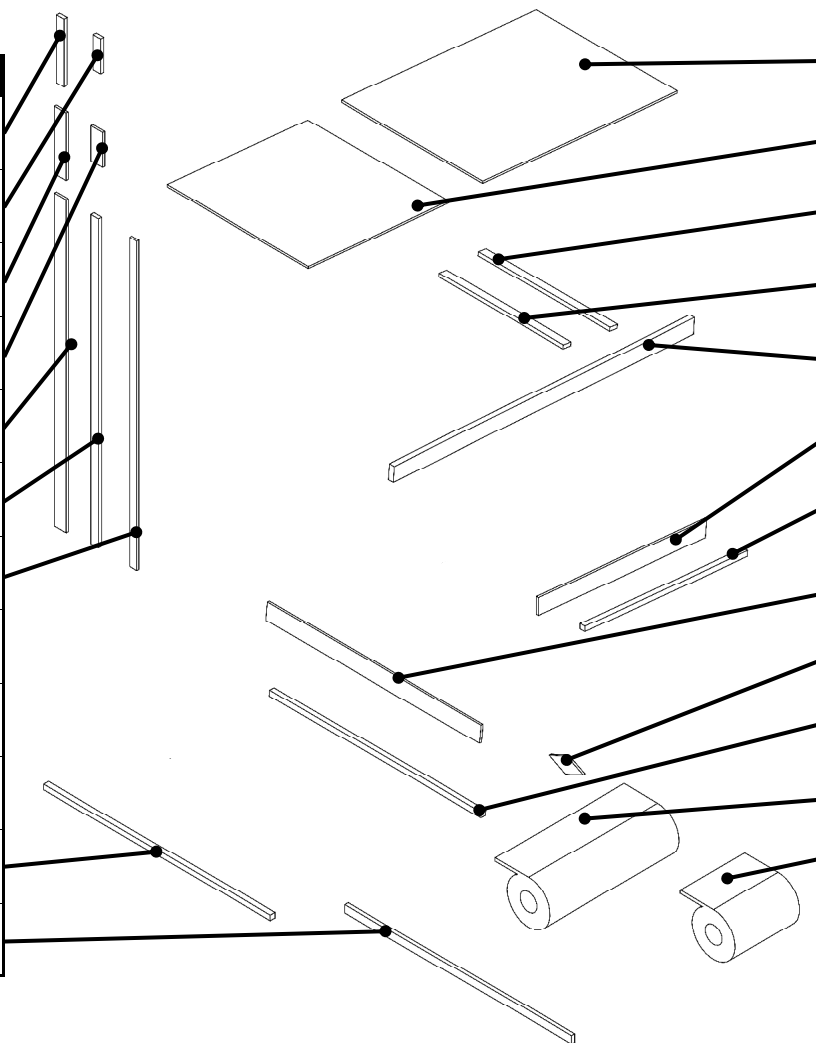

Pos.	Details in cm	Pcs.
27.	83 x 115	3
28.	83 x 83	3
29.	1,9 x 45 x 77	1
30.	1,9 x 45 x 73	2
31.	2,8 x 80 x 177	4
32.	1,2 x 9 x 99	4
33.	2,8 x 2,8 x 96	4
34.	1,2 x 9 x 125	2
35.	1,2 x 9 x 20	3
36.	2,8 x 2,8 x 124	4
37.	100 x 260	2
38.	50 x 260	1

39.
Ø4,0x25mm
18 Pcs

40.
Ø4,5x50mm
87 Pcs

41.
Ø3,5x35mm
191 Pcs

42.
2 Pcs

43.
1 Pcs

44.
1 Pcs

45.
4 Pcs

46.
1 Pcs

48.
Ø3x10mm
170 Pcs

PRP6x8

1.

4 mm

50 mm x 6 St

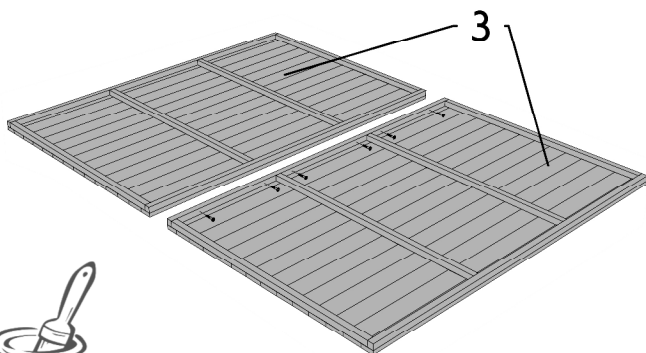

2.

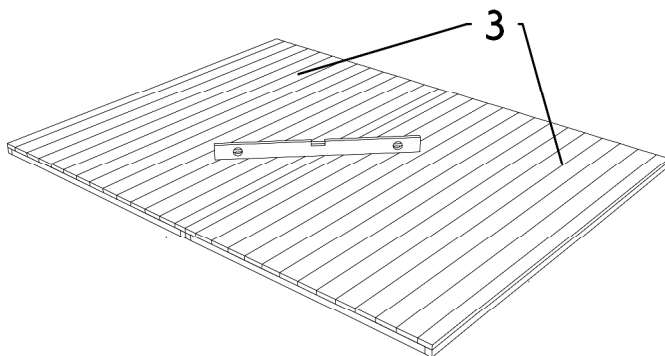

3.

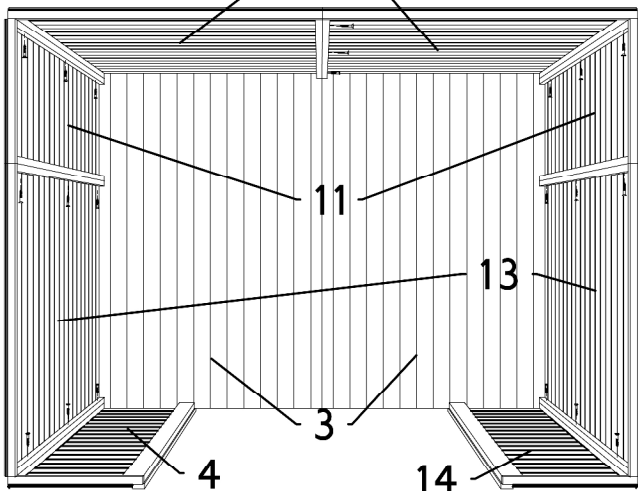

4.

4 mm

50 mm x 3 St

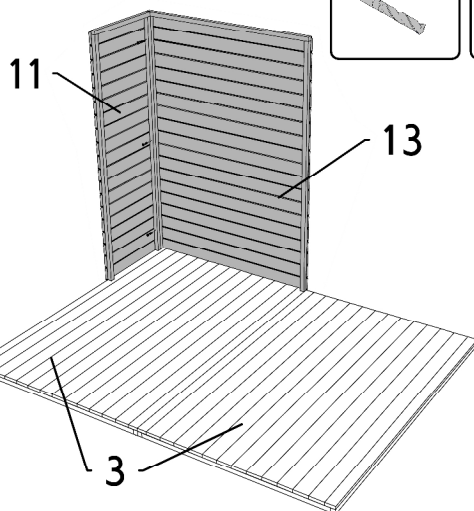

5.

4 mm

50 mm x 6 St

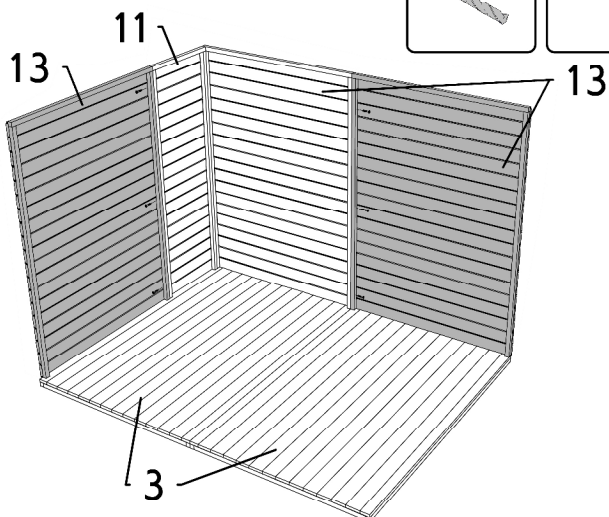

6.

4 mm

50 mm x 6 St

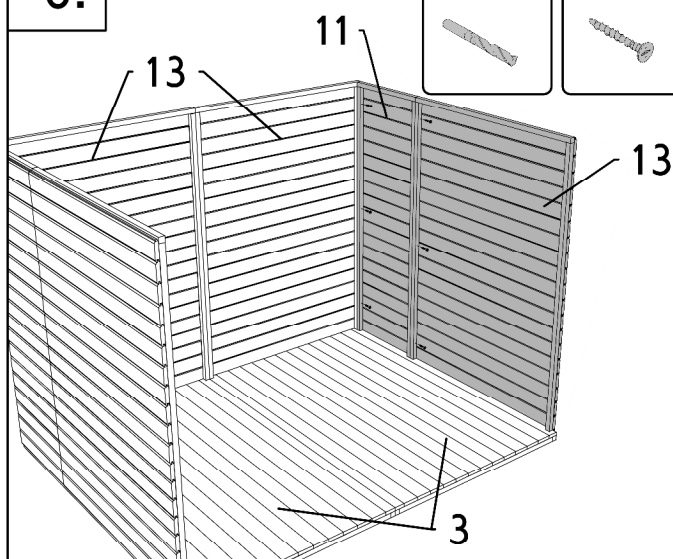

PRP6x8

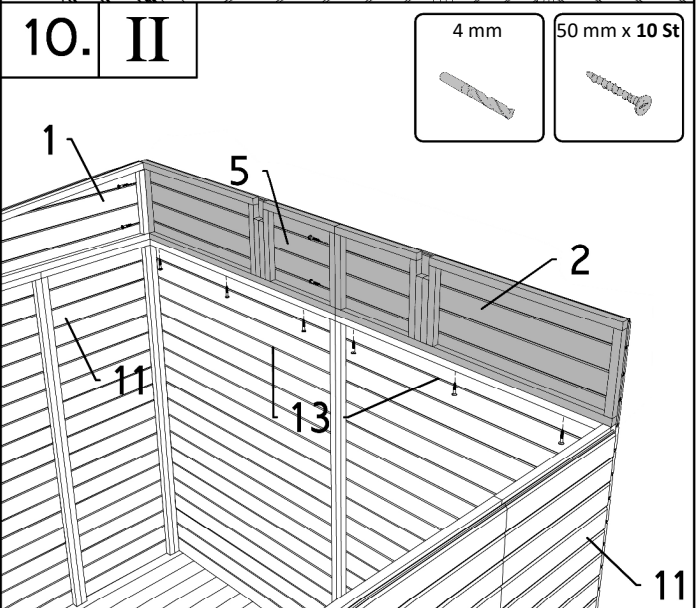
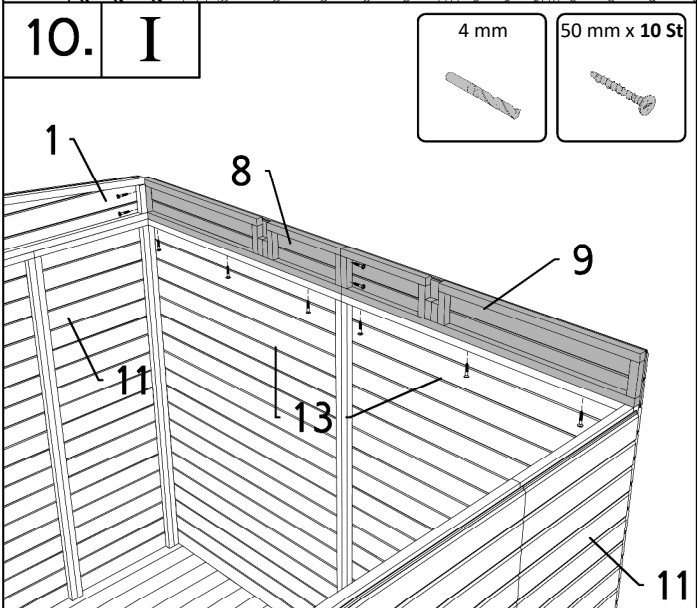
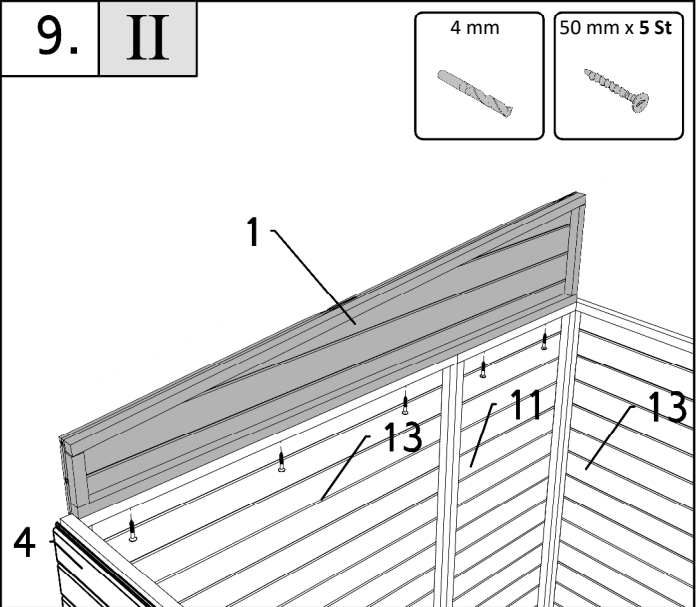
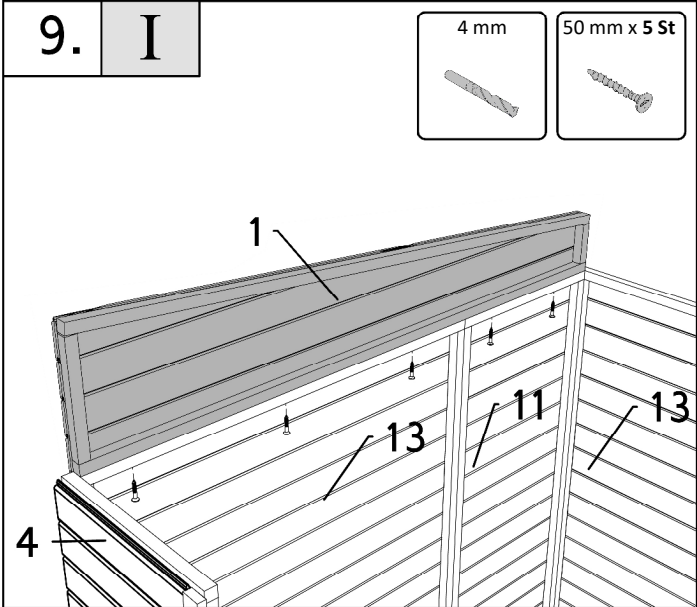
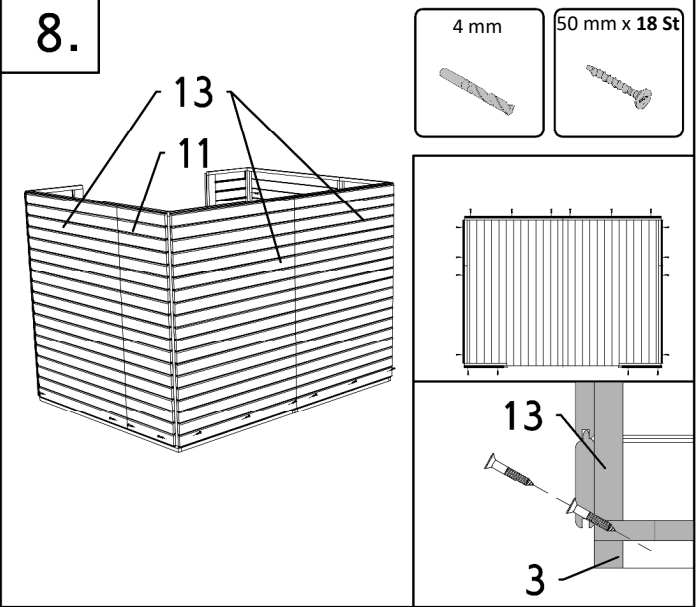
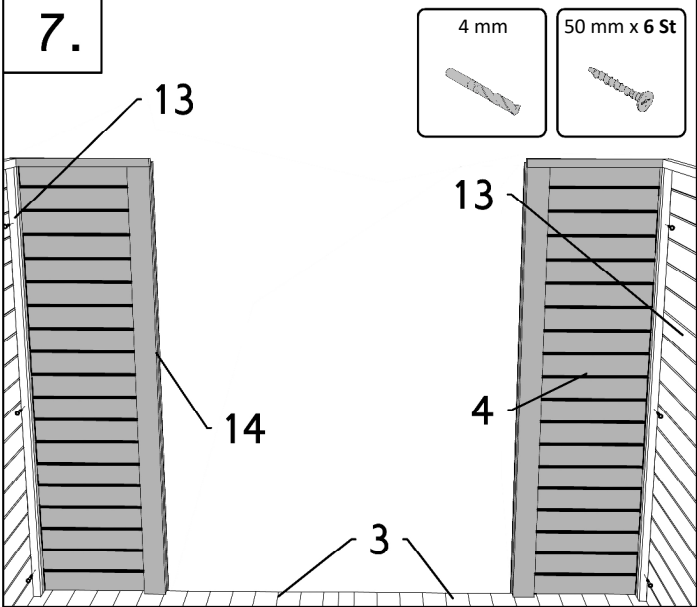

PRP6x8

11. I

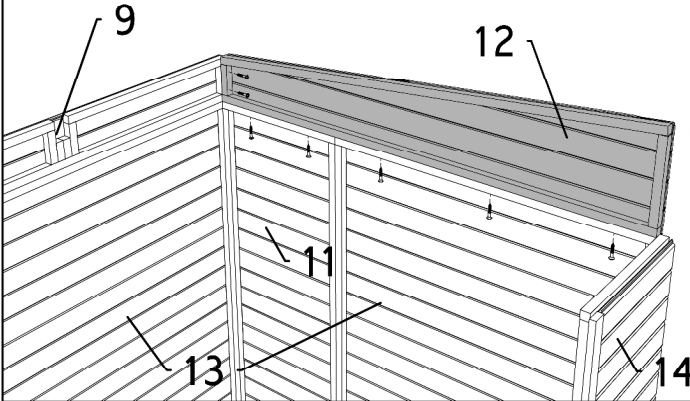
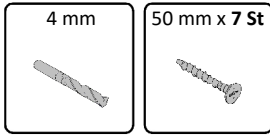

11. II

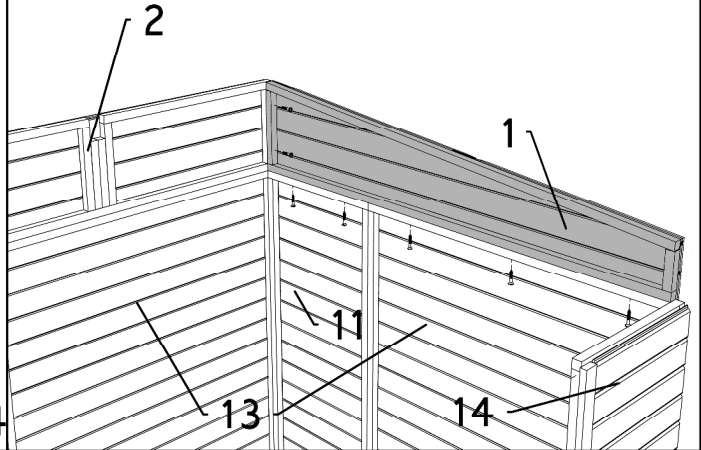
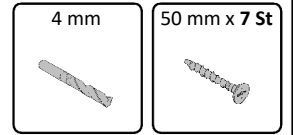

12. I

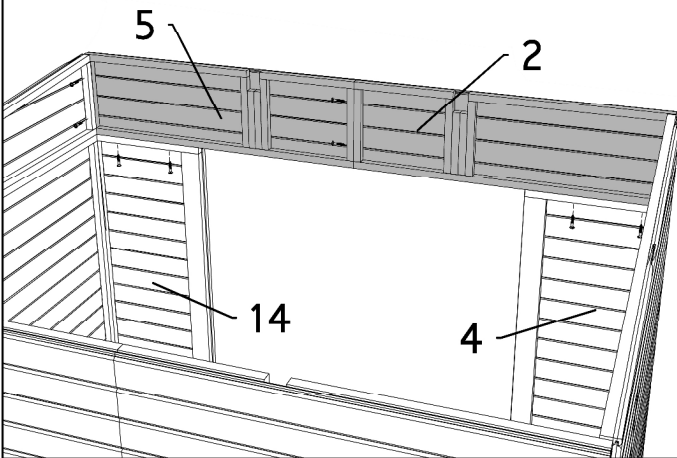
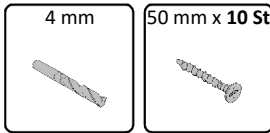

12. II

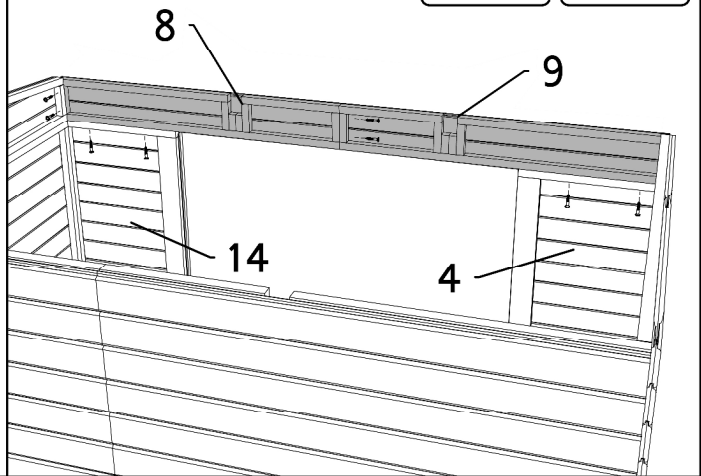
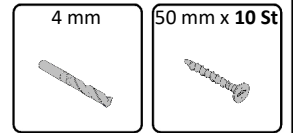

13. I

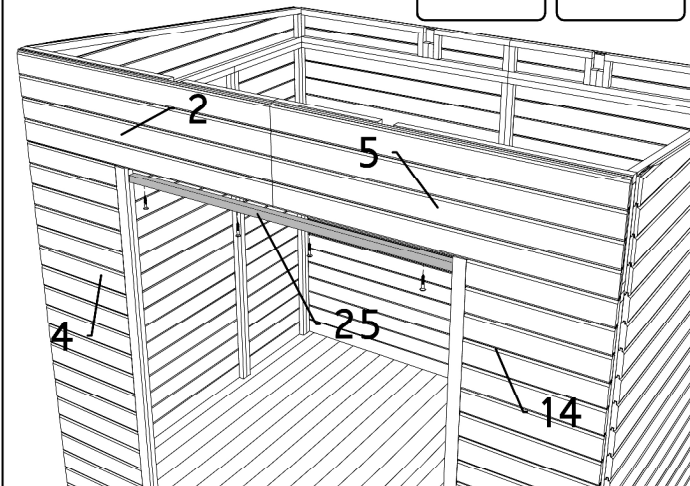
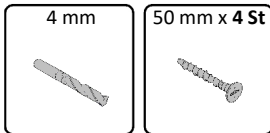

13. II

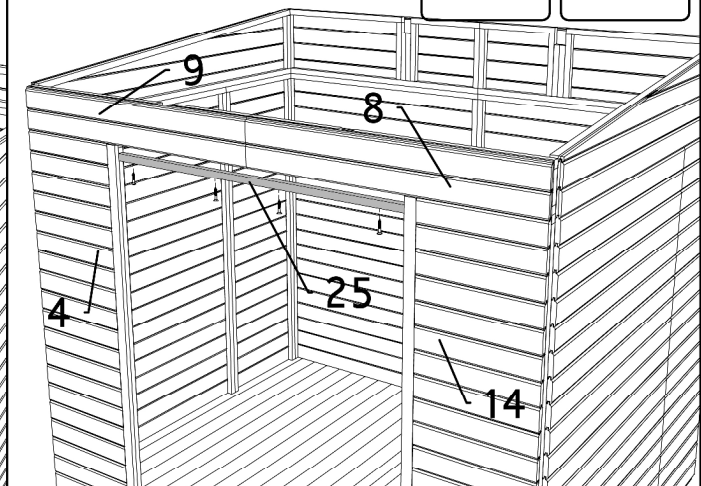
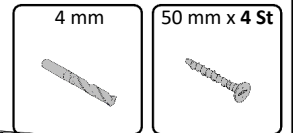

PRP6x8

14. x2

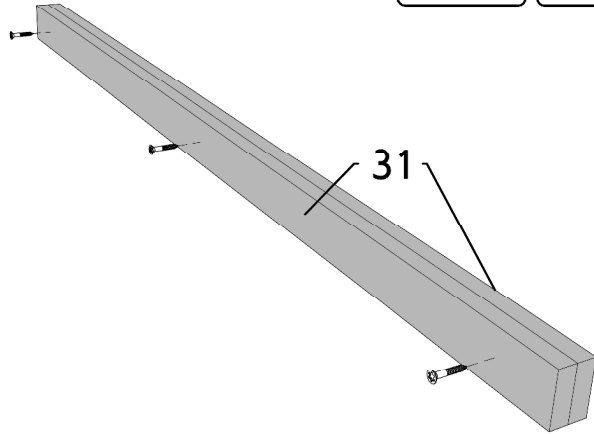
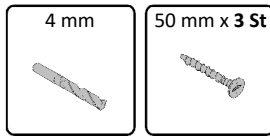

15.

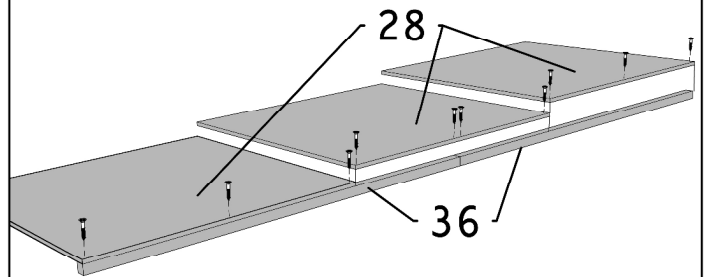
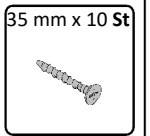

16. I

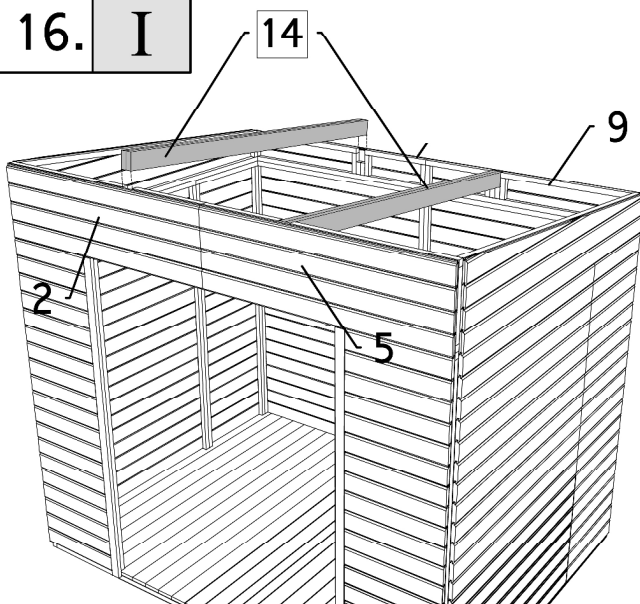

16. II

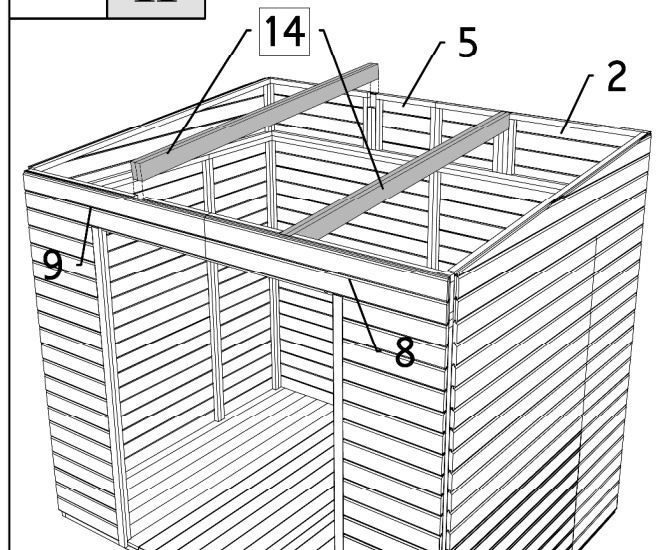

17. I

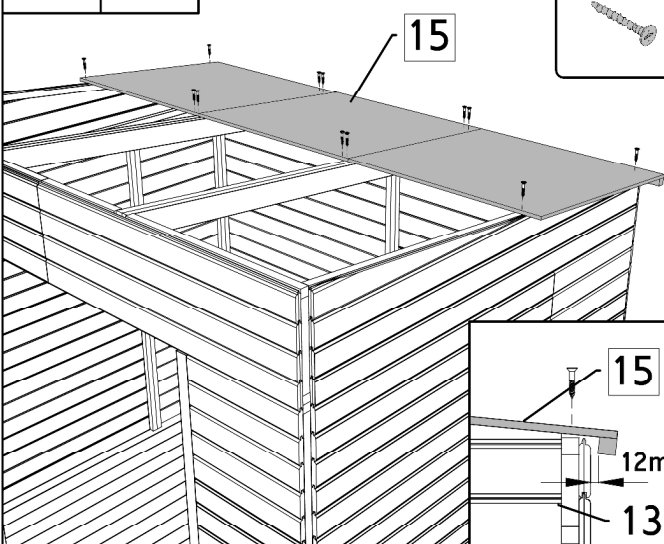

17. II

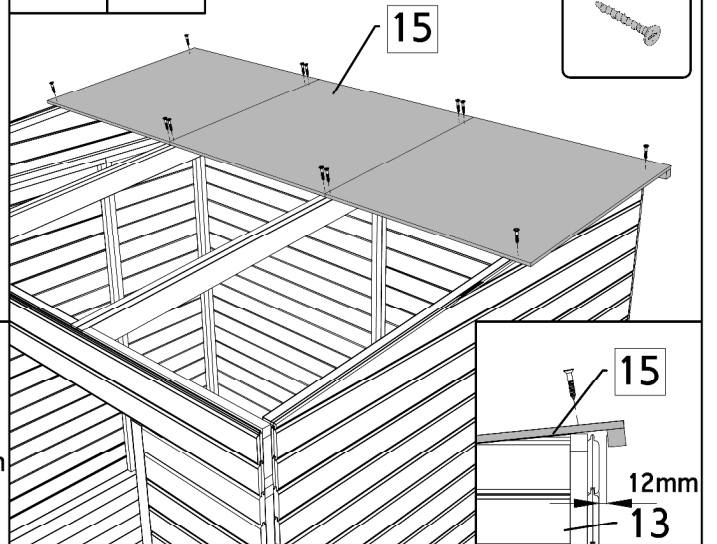
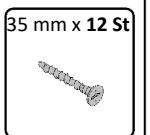

PRP6x8

18.

35 mm x 4 St

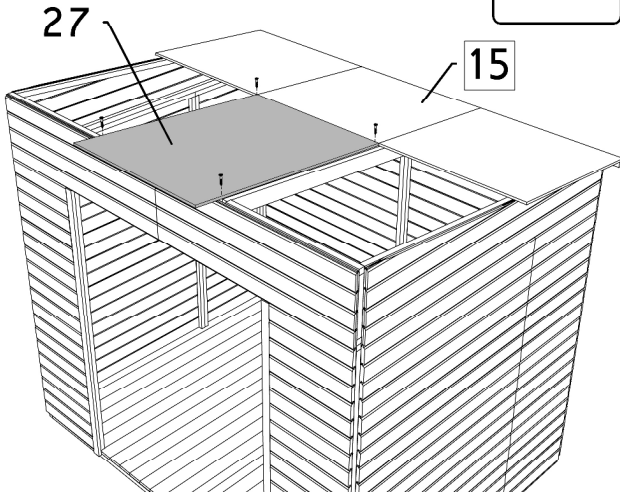

19.

35 mm x 8 St

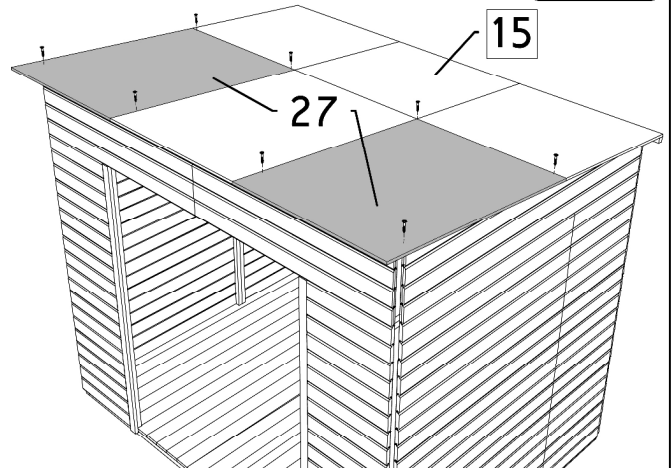

20.

35 mm x 18 St

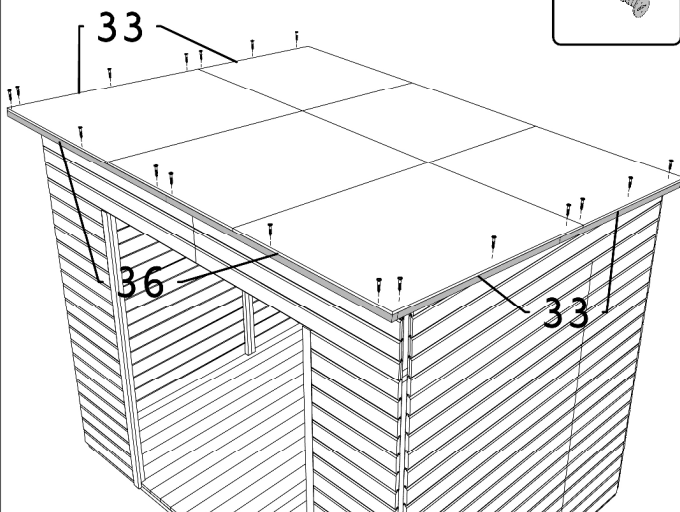

21.

25 mm x 18 St



22. I

35 mm x 23 St

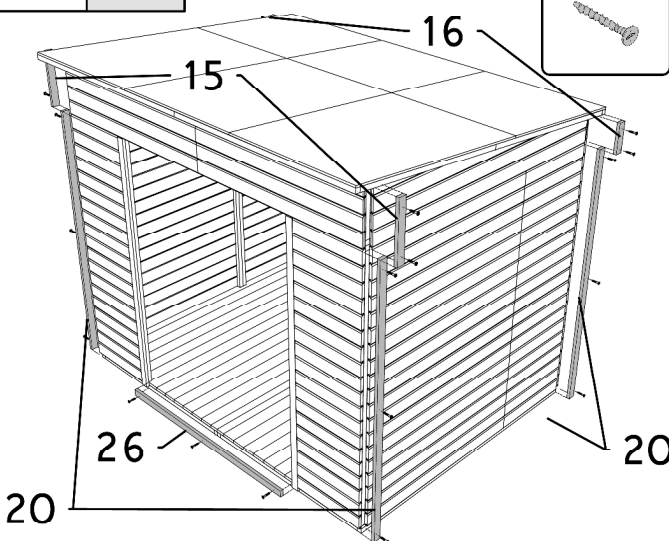

22. II

35 mm x 23 St

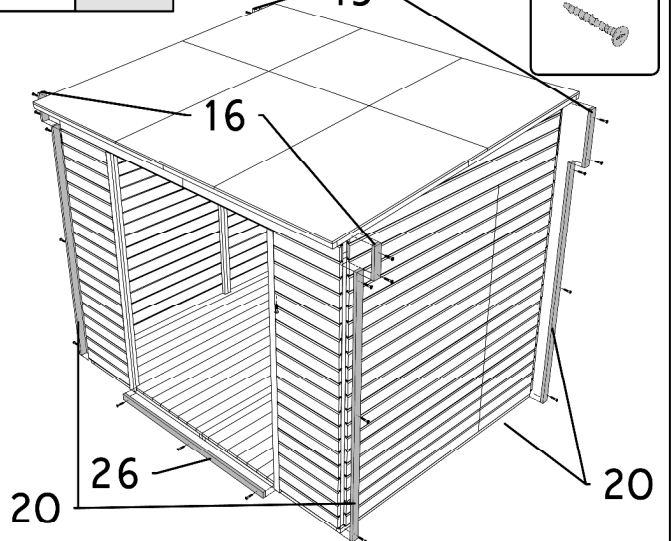

PRP6x8

24. I

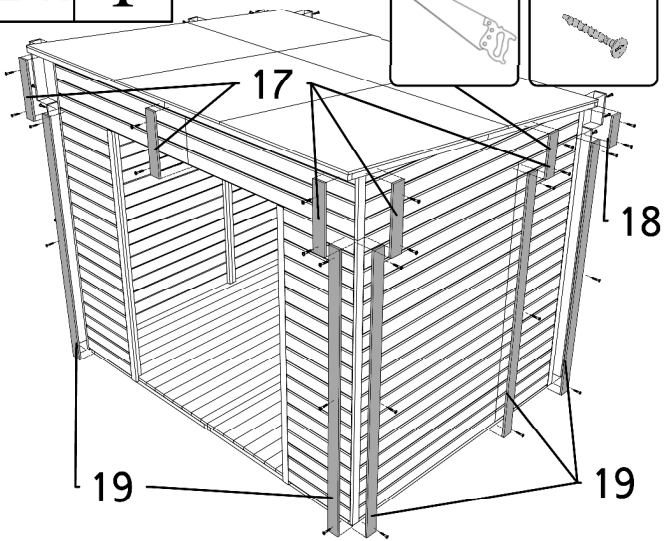
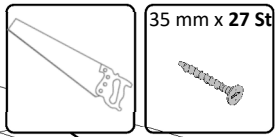

24. II

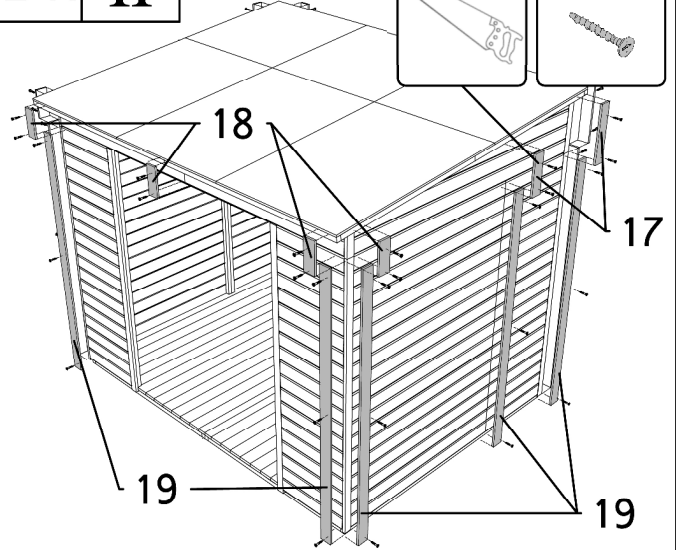
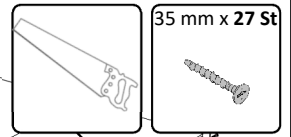

25. I

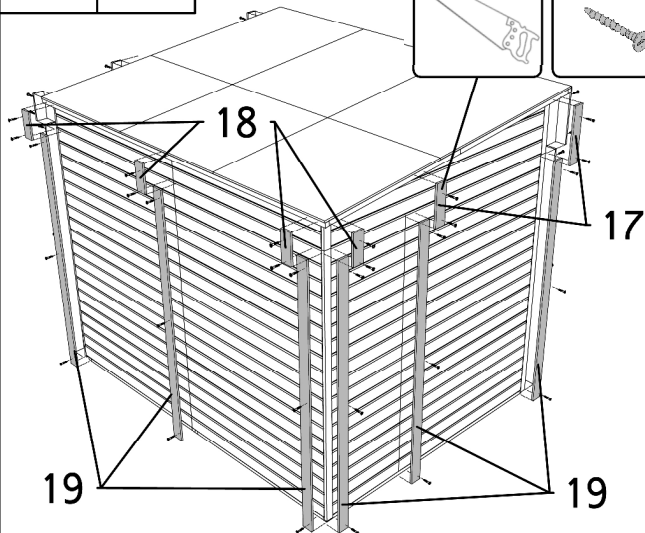
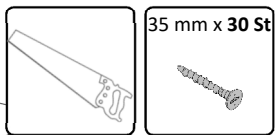

25. II

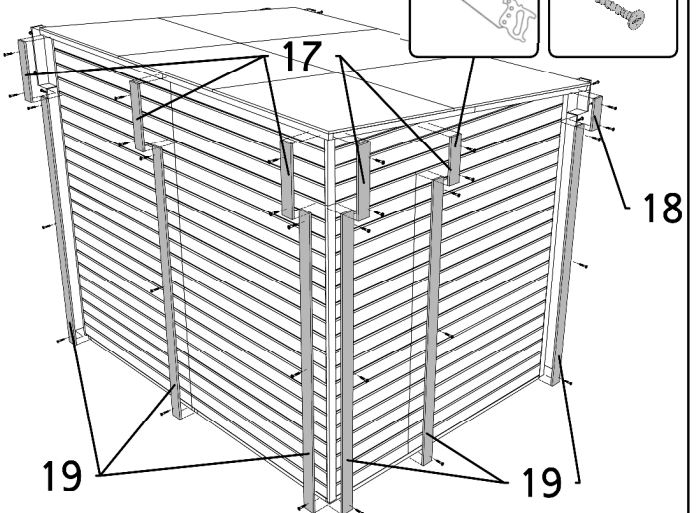
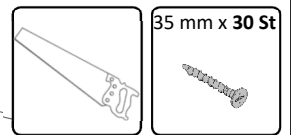

26.

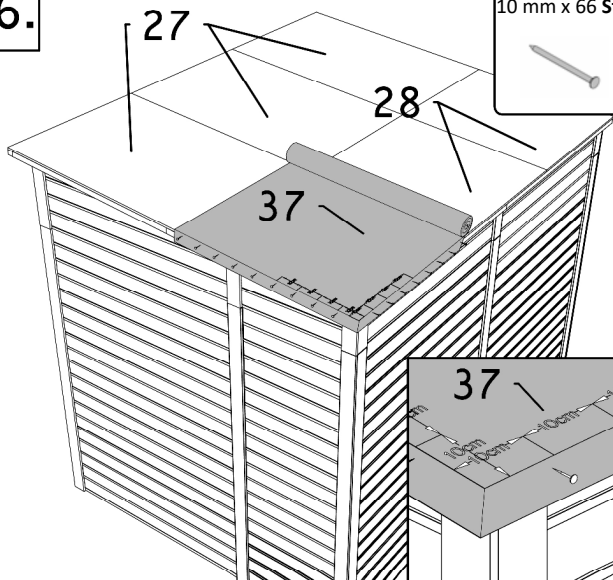
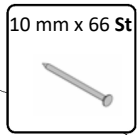

27.

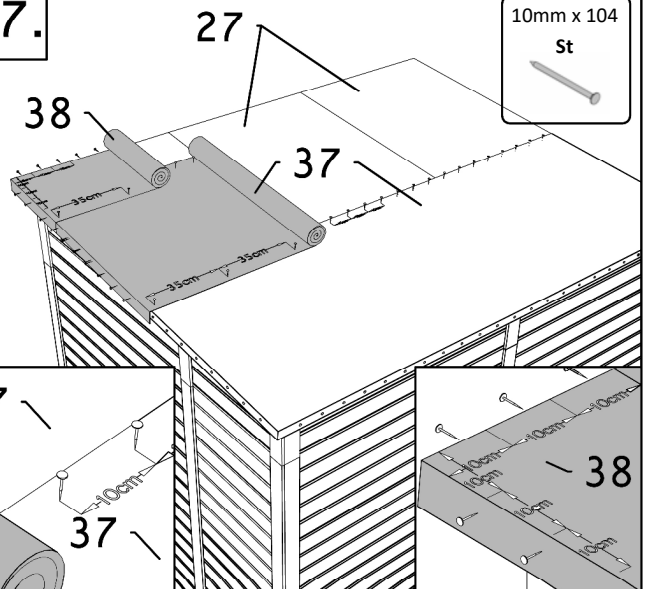
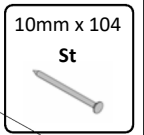

PRP6x8

28. I

35 mm x 18 St

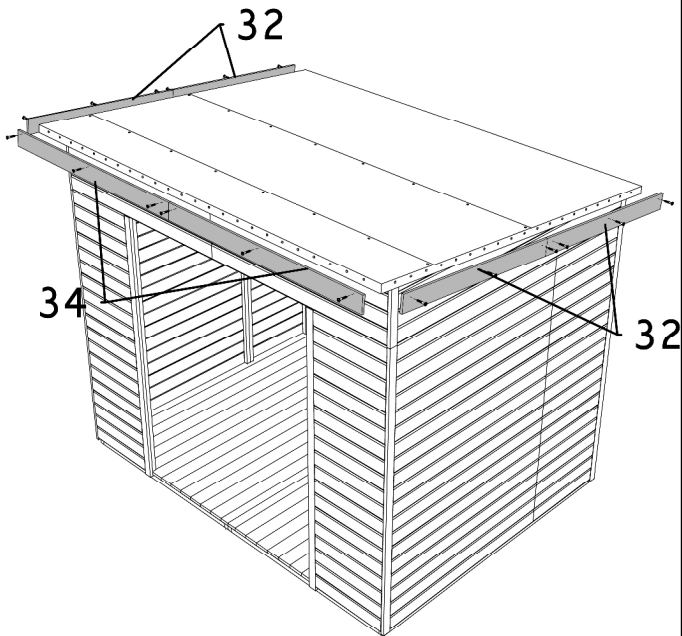

28. II

35 mm x 12 St

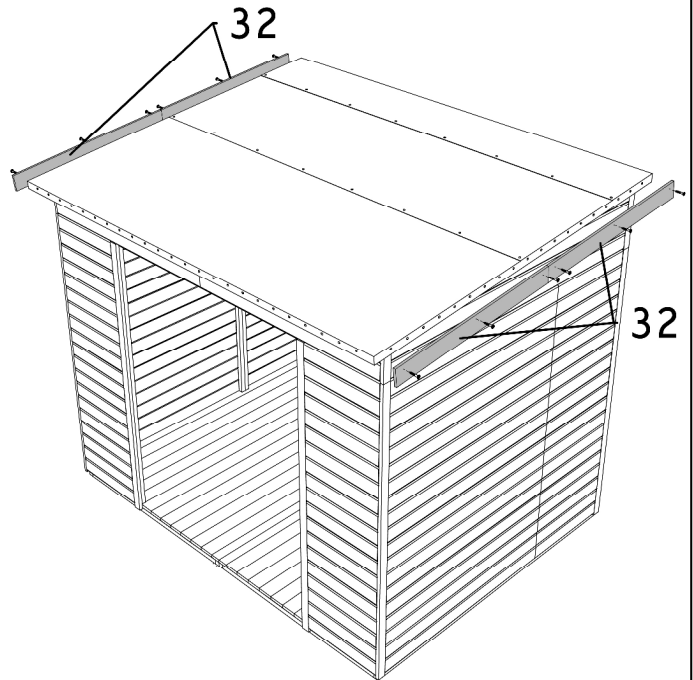

29. I

35 mm x 6 St

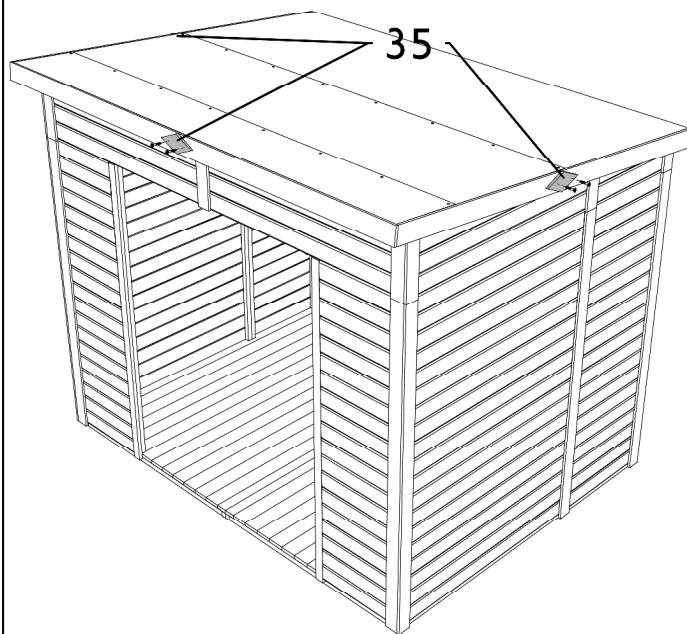

29. II

35 mm x 4 St

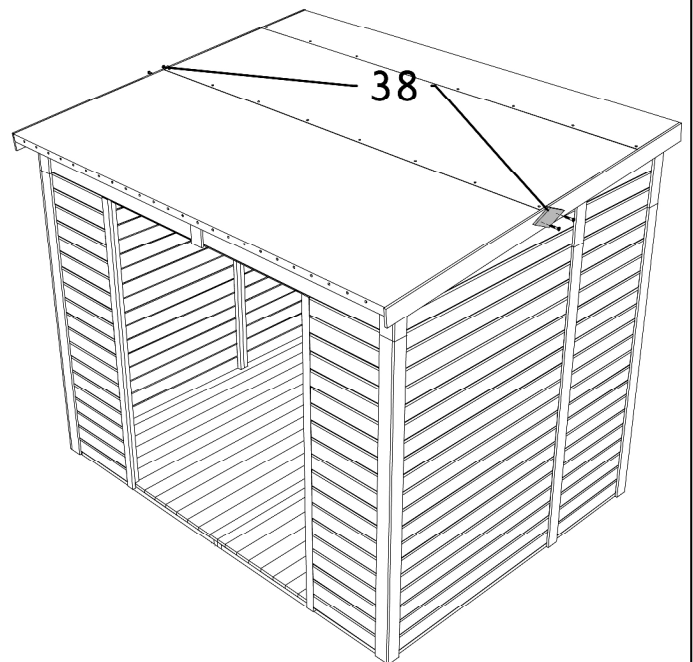

PRP6x8

31. NB!

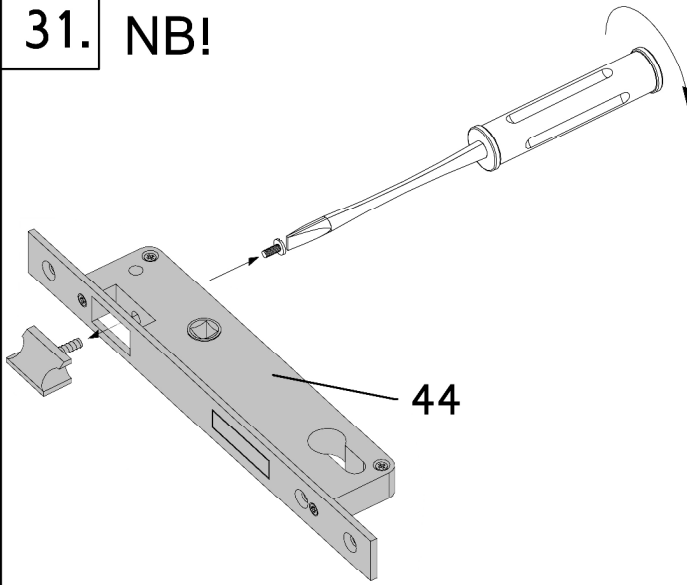

32.

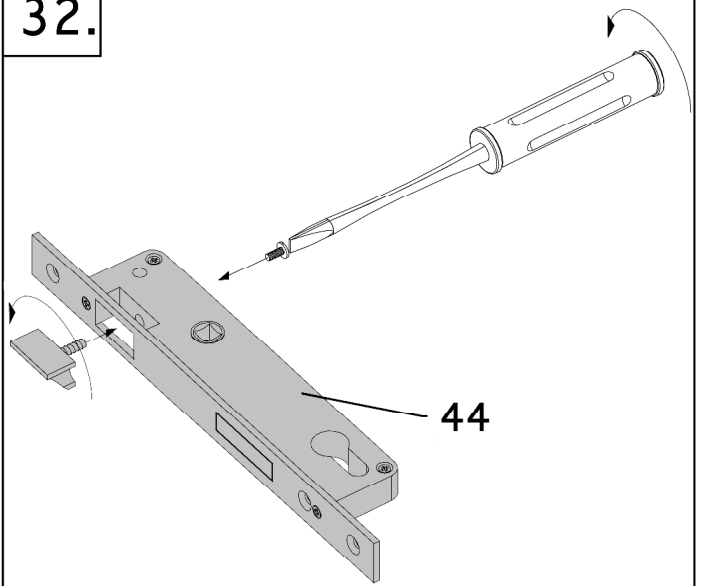

33.

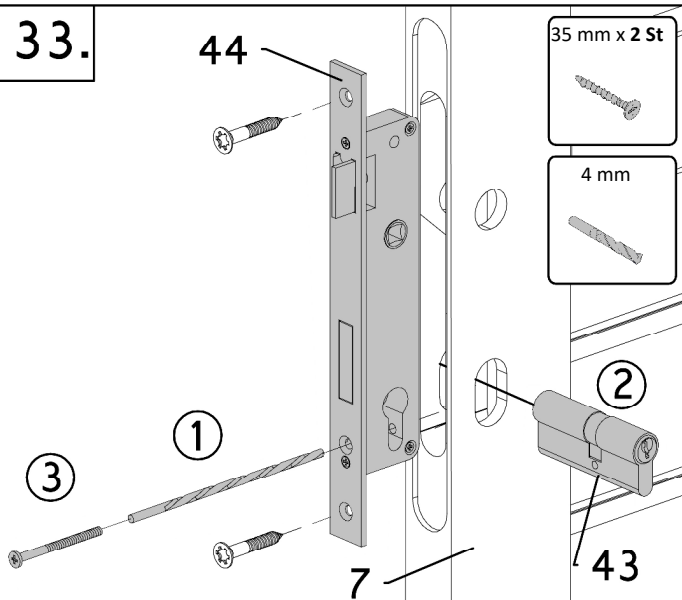

34.

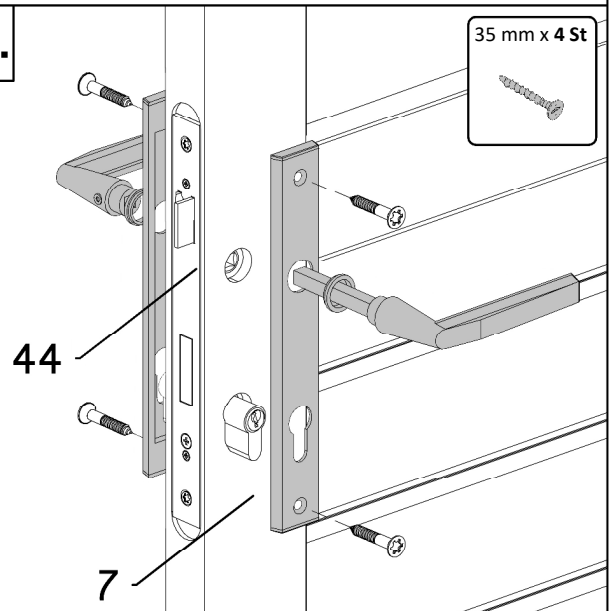

35. x2

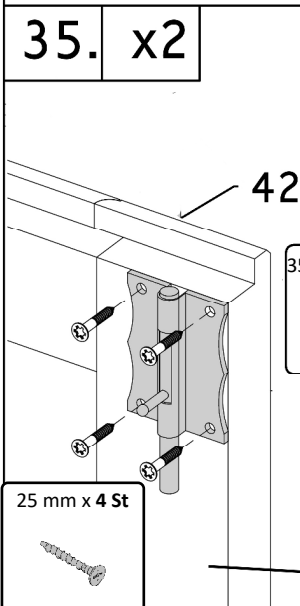

36.

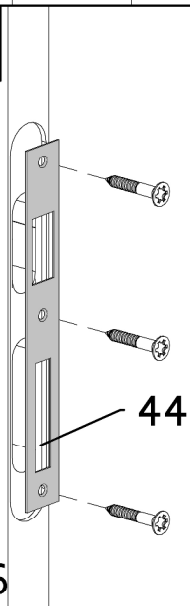

37. x4

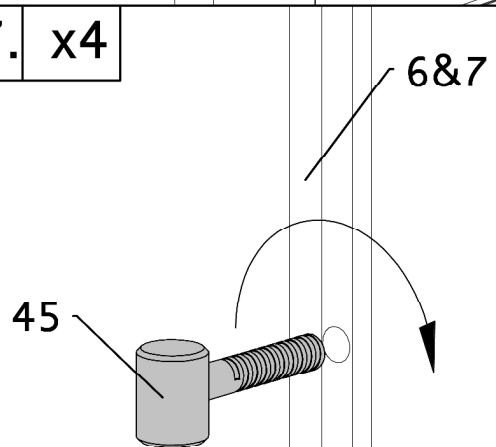

PRP6x8

